

# High Performance Brake Systems



Release  
n. 01/2010



**brembo**

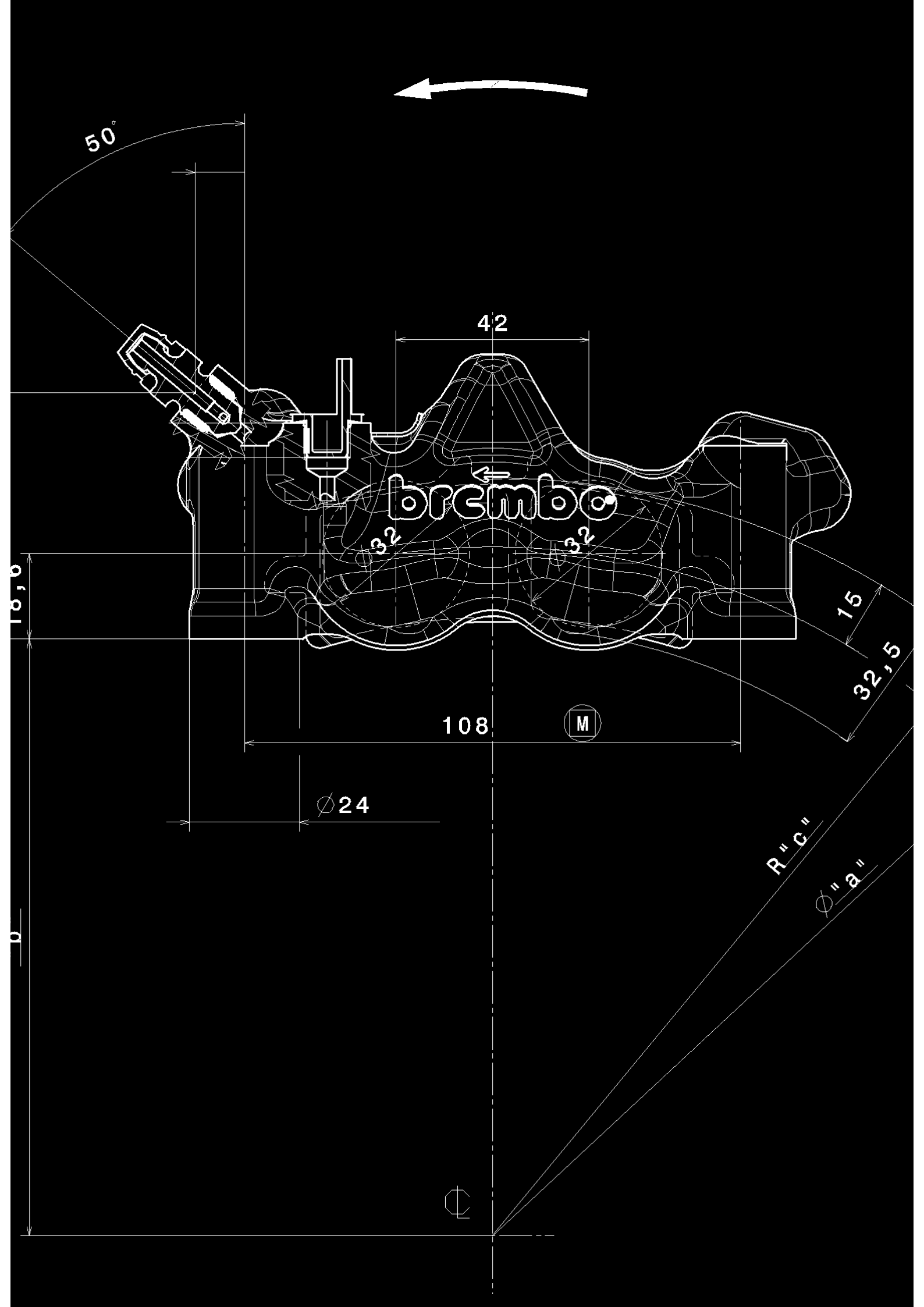

# Index

Introduction	+ + + + + + + + + + + + + +	<b>2</b>
Installation instructions	+ + + + + + + + + + +	<b>4</b>
Section 1: Speed	+ + + + + + + + + + + + + +	<b>9</b>
Section 2: Motard	+ + + + + + + + + + + + + +	<b>55</b>
Section 3: Off Road	+ + + + + + + + + + + + + +	<b>63</b>
Limited Warranty	+ + + + + + + + + + + + + +	<b>72</b>



### **Brembo. Number One for brakes.**

Brembo is the world's leading maker of braking systems for motor cars, motorcycles and commercial vehicles. The organization operates on 3 continents, and sales network cover 70 national territories around the world.

### **Research never ceases.**

Brembo has always invested in R&D, in its quest to offer a product at the leading edge, guaranteeing safety and performance. Research and Development is the focus for 4,8% of investments, and the efforts of 430 engineers.

### **Brembo, racing, and winning.**

For 30 years and more, Brembo has been equipping the cars and bikes of elite drivers and riders competing in motor sports at world championship level.

### **Brembo - all done in-house.**

The entire manufacturing process is an in-house operation: design, development, testing, machining, quality control, distribution, service.

### **Brembo High Performance**

The experience accumulated through years of intensive research in the competition field has allowed us to create product lines that are differentiated on the basis of the application types and different research and development procedures adopted. Thanks to the results obtained, motorbike sports enthusiasts who insist on replacing original brake systems with Brembo High Performance equipment are able to improve their riding style in terms of performance and safety while also ramping up the overall aesthetic appeal of their machines.

For any further explanations please refer to our website [www.brembo.com](http://www.brembo.com)  
Racing and HP brake upgrade sections



**Brembo è il leader dei freni.**

Brembo è leader mondiale dei sistemi frenanti per auto, moto e veicoli commerciali. È attiva con siti produttivi e uffici commerciali in 3 continenti, e la distribuzione avviene in 70 paesi del mondo.

**La ricerca non si ferma mai.**

Da sempre, Brembo investe in Ricerca e Sviluppo, per realizzare un prodotto all'avanguardia, sicuro e performante. Al reparto R&D dedica il 4,8% degli investimenti e il lavoro di 430 ingegneri.

**Brembo vince nel racing.**

Da più di 30 anni, Brembo equipaggia le auto e le moto dei grandi piloti nelle più importanti gare mondiali di automobilismo e motociclismo.

**Tutto è prodotto in Brembo.**

Tutto il processo produttivo è integrato all'interno dell'azienda: progettazione, sviluppo, test, lavorazione, controllo qualità, distribuzione, assistenza.

**Brembo High Performance e Racing.**

L'esperienza accumulata in anni di intensa attività agonistica, unita alla continua attività di ricerca, ha portato Brembo a sviluppare linee di prodotto differenziate in funzione della tipologia di applicazione. Grazie ai risultati ottenuti, gli appassionati di moto possono ora sostituire i sistemi frenanti di primo equipaggiamento con componenti Brembo High Performance o Racing, apportando notevoli miglioramenti alle proprie prestazioni e sicurezza di guida, ed all'aspetto estetico dei propri mezzi.



Per ogni ulteriore informazione consultate il sito [www.brembo.com](http://www.brembo.com) sezioni Racing e HP brake upgrade

## 1. SCOPE

To show the correct procedures for the mounting and use of BREMBO front braking systems for racing motorcycles.

## 2. RESERVOIR

### 2.1. Choice of the reservoir

The capacity of the reservoir must be such that when the brake fluid is between the MIN and MAX levels (with the cover in a horizontal position) the volume is at least equal to that required by the brake pistons in case of maximum pad and rotor wear.

### 2.2. Mounting the reservoir

- a. The reservoir must be mounted on the motorcycle in such a way that with the motorcycle in a vertical position, the reservoir upper border is horizontal.
- b. With the motorcycle in a vertical position, the MIN level indication on the reservoir must be higher than the master cylinder inlet pipe fitting.

### 2.3. Inspections

Verify that the brake fluid can flow freely within the reservoir, from the upper border down to the MIN level. This happens when air can flow from the exterior to the inside of the reservoir membrane (if this air flow is hampered, a vacuum could be created and this would not allow fluid to flow downwards). The popular bands that are usually wrapped around brake fluid reservoirs (if they are too close to the reservoir cover) could hamper this "breathing" of the reservoir and thus the master-cylinder would not be fed properly.

## 3. MASTER-CYLINDER

### 3.1. Mounting

- a. Mount the master-cylinder to the handlebar keeping in mind that it can be positioned in any manner requested by the driver.
- b. Adjust the lever distance from the handlebar by turning the adjusting nut either clockwise or anticlockwise according to the driver's requirements; it must be noted that the lever positioning must allow the driver to generate the pressure necessary to stop the motorcycle.

### 3.2. Inspections

Pull the lever until it touches the grab handle on the handlebar and verify that the master-cylinder piston stroke is smooth.

## 4. STEEL DISCS

### 4.1. Mounting

- a. Verify that the disc bell and wheel mounting faces are free from burrs and dents, otherwise these surfaces should be reconditioned.
- b. The disc must fit onto the wheel easily.
- c. The disc must be mounted onto the wheel by using bolts having a diameter which corresponds to the holes in the mounting bell; the bolts must be of the quantity and length 2/7 as prescribed by the motorcycle manufacturer and must be tightened at the appropriate torque.
- d. It is suggested to apply thermal paints on the disc outer circumference in order to monitor operating temperatures.

## 1. SCOPO

Descrivere le corrette procedure per il montaggio e l'uso degli impianti frenanti dedicati alle competizioni.

## 2. SERBATOIO OLIO

### 2.1. Scelta del serbatoio

La capacità del serbatoio deve essere tale da garantire che il livello del fluido freno scenda dal MAX. e non oltre il MIN., anche in caso di consumo massimo sia delle pastiglie che del disco.

### 2.2. Montaggio serbatoio

- a. Il serbatoio deve essere montato in maniera tale da risultare verticale quando la motocicletta si trova in posizione di marcia.
- b. Con la motocicletta in ordine di marcia, la tacca di MIN. del serbatoio deve trovarsi al di sopra del punto d'ingresso olio nella pompa.

### 2.3. Ispezioni

Verificare che l'olio possa liberamente fluire attraverso il serbatoio.

Può accadere che il passaggio aria permesso dalla membrana posta sotto il tappo s'interrompa, generando così una sorta di "effetto vuoto" che impedisce questo passaggio.

Attenzione alle classiche bande in spugna poste sul serbatoio stesso: queste non devono essere poste troppo vicine al tappo di chiusura, potrebbero impedire all'aria di entrare.

## 3. POMPA FRENO

### 3.1. Montaggio

- a. Montare la pompa sul manubrio verificando che non ci siano impedimenti alla possibilità di ruotarla ed adeguarla alle necessità del pilota.
- b. Regolare la distanza della leva dal manubrio, agendo sull'apposito registro, in modo che il pilota abbia il giusto feeling con il freno.

### 3.2. Ispezioni

Azionare la leva freno a fondo, fino a farla toccare contro il manubrio, in modo da verificare che il pistoncino della pompa faccia tutta la corsa con movimento "morbido", senza impuntamenti di sorta.

## 4. DISCHI IN ACCIAIO

### 4.1. Montaggio

- a. Controllare che non ci siano bave o altri residui di lavorazione tra le facce d'accoppiamento della ruota e della campana del disco.
- b. Il disco deve montare sulla ruota facilmente.
- c. I fori di fissaggio del disco devono avere un diametro adeguato alla vite, le viti devono essere della qualità e della lunghezza adeguata al lavoro che devono svolgere ed il loro serraggio effettuato con una chiave dinamometrica, tarata in maniera corretta.
- d. È consigliabile applicare le vernici termoviranti in modo da controllare la temperatura d'esercizio.

## 4.2. Inspections

The disc must be "floating" even after it has been mounted onto the wheel: axial clearance between disc and bell must be 0.2 mm MIN.

## 4.3. Note

The discs must not be subjected to mechanical shock, and must not be contaminated with liquids, oil and grease.

## 5. CALIPERS

### 5.1. Mounting

- Mount the caliper onto the fork such that the arrow marked on the outer half-caliper corresponds to the forward direction of rotation of the brake disc (the disc must enter the caliper through the side corresponding to the smaller piston and exit through the other side corresponding to the larger piston).
- The caliper must be mounted in a symmetrical position with respect to the disc center line: Misalignment must be 0.15 mm MAX (see fig. 1).

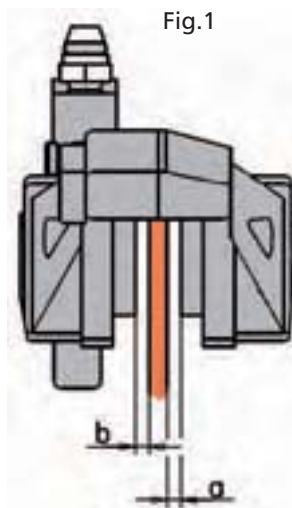

$a \neq b : 0,3 \text{ mm MAX}$

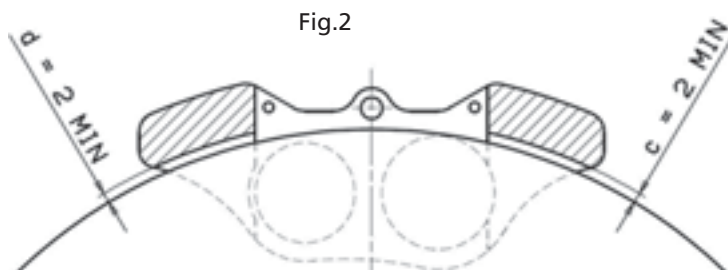

$c \neq d : 0,4 \text{ mm MAX}$

- The clearance between disc outer circumference and caliper bridge must be 2 mm MIN, with a difference between the two sides of 0.4 mm MAX (see fig. 2).
- The caliper mounting bolts must be tightened to the prescribed torque.
- Apply thermal tape on the internal half-caliper in order to monitor operating temperatures: these can be supplied by BREMBO under part number R 02.5168.11/12 (for the application area see fig. 3).

## 6. PADS FOR STEEL DISCS

### 6.1. Mounting

- The pads must be inserted inside the caliper without any interference and without requiring any excessive force.
- The pads must not protrude from the disc; the disc may protrude from the pads by 0,5 mm. MAX (see fig. 4 and fig. 5); to obtain the correct positioning of the caliper, as described above, it can be moved relative to the fork by using the existing clearance between the fixing holes and the caliper bolts.

### 6.2. Inspection

Verify that the pad pin and cotter pin have been correctly installed; it is suggested to tie the pad pin to the caliper and pads with iron wire through the appropriate holes.



Fig.4

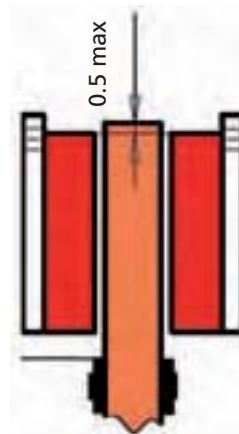

Fig.5

## 4.2. Ispezioni

Il disco deve poter flottare liberamente dopo il montaggio. La flottanza minima deve essere di 0,2 mm.

## 4.3. Note

Il disco non deve essere stato soggetto a shock meccanici oppure contaminato da liquidi corrosivi, olio o grasso.

## 5. PINZE

### 5.1. Montaggio

- Montare le pinze in modo che la freccia marcata sulla parte esterna della pinza sia in fase con il senso di rotazione della ruota (nel caso di pistoni differenziati il disco deve "entrare" del lato del pistoncino di diametro inferiore e, conseguentemente, uscire da quello di diametro maggiore).
- La pinza deve essere montata in modo che il suo asse di mezzeria corrisponda con quello del disco (vedi fig. 1). È ammesso undisallineamento max. di 0,15 mm.

Fig.3

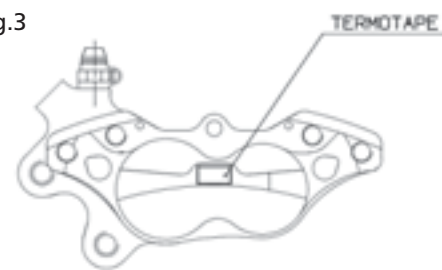

- La distanza tra il diametro esterno del disco ed i lati della pinza deve essere almeno di 2 mm., mantenendo la differenza entro 0,4 mm. (vedi figura 2).
- Le viti di fissaggio della pinza devono essere serrate con la chiave dinamometrica alla coppia prescritta.
- Applicare all'interno della pinza (vedi figura 3) gli adesivi indicatori della temperatura max. raggiunta (thermo tape), in modo da monitorare la temperatura d'esercizio.

## 6. PASTIGLIE PER DISCHI IN ACCIAIO

### 6.1. Montaggio

- Le pastiglie devono poter essere inserite nella pinza senza interferenza e senza dover applicare una forza eccessiva.
- Le pastiglie, una volta montate, non devono fuoriuscire oltre il diametro esterno del disco bensì starne al di sotto di circa 0,5 mm. Per ottenere questa posizione si sfrutta il gioco esistente tra i bulloni di fissaggio ed i fori sul supporto (vedi figure 4/5).

### 6.2. Ispezione

Verificate che il perno di sostegno pastiglie e la copiglia di ritengo siano correttamente montati. Sugeriamo di mettere i vari componenti in sicurezza utilizzando filo di ferro passato negli appositi fori.

## 7. RESERVOIR TO MASTER-CYLINDER CONNECTION

### 7.1. Choice of tubing

Black rubber tubing, compatible with brake fluid, could be used; transparent plastic tubing could also be used: The rubber tubing is the better solution, but it is not possible to see through it, and so you could not see possible air bubbles; the transparent plastic tubing is better in this sense but since it is not compatible with brake fluid, sweating could occur and so it would have to be changed periodically.

### 7.2. Mounting

The tube must connect the reservoir outlet with the master-cylinder inlet; the appropriate hose clamps must be used at both ends.

## 8. MASTER-CYLINDER/CALIPER CONNECTION

### 8.1. Choice of tubing

- It is suggested to use teflon flexible tubing with steel-braided covering.
- The flexible tubing must have an internal diameter of 3 mm MIN.

### 8.2. Mounting

- Pipe fittings must be tightened to the prescribed torque.
- The copper or aluminium washers can only be used once.

## 9. BRAKE FLUID

### 9.1. Choice

- Use only high boiling point DOT 3 or DOT 4 brake fluids.
- Use only brake fluid from a new and sealed container.
- Change brake fluid before each race.

### 9.2. Notes

Use of liquids other than brake fluids will damage the braking system components.

## 10. BRAKING SYSTEM BLEEDING

### 10.1. Procedure

To bleed the brakes proceed as follows:

- Turn the handlebar until the border of the reservoir is horizontal.
- Fill the reservoir with brake fluid ; during bleeding avoid letting the brake fluid level go below the MIN level.
- Apply the brakes several times to fill the braking system partially.
- Insert a flexible transparent tube to the bleed screw.
- Bleed through one bleed screw at a time:
  - Pull the brake lever all the way and keep it in this position;
  - Unscrew the bleed screw, let some brake fluid flow out (initially only air will come out) and then tighten the bleed screw (lightly);
  - Let go the brake lever, wait a few seconds and repeat the above steps until no air bubbles will come out of the bleed screw.
- Tighten the bleed screw to the prescribed torque and fill up the reservoir with brake fluid.;

## 7. COLLEGAMENTO SERBATOIO OLIO/POMPA

### 7.1. Scelta del tubo

Utilizzare il tubo in gomma nera compatibile con il fluido freni. I tubi trasparenti sono raramente compatibili con il fluido freni e se utilizzati, devono essere sostituiti periodicamente.

### 7.2. Montaggio.

Il tubo deve collegare l'uscita del serbatoio con l'entrata della pompa, appropriate fascette stringitubo devono essere utilizzate alle due estremità.

## 8. COLLEGAMENTO POMPA/PINZA

### 8.1. Scelta del tubo

- Suggeriamo fortemente di utilizzare tubazioni con l'interno in teflon e con l'esterno rivestito in maglia d'acciaio.
- Il diametro della tubazione interna deve essere almeno di 3 mm.

### 8.2. Montaggio

- I bocchettoni devono essere serrati con la coppia appropriata.
- Le guarnizioni, sia in rame che in alluminio, devono essere utilizzate una sola volta.

## 9. FLUIDO FRENI

### 9.1. Scelta

- Utilizzare esclusivamente DOT 4 ad alto punto d'ebollizione.
- Utilizzare sempre fluido freni proveniente da confezioni nuove.
- Sostituire il fluido freni prima d'ogni gara.

### 9.2 Note

L'utilizzo di liquidi diversi dal fluido freno potrebbe provocare il danneggiamento dei componenti dell'impianto frenante.

## 10. SPURGO IMPIANTO

### 10.1. Procedura

Per effettuare uno spurgo corretto procedere come segue:

- Girare il manubrio fino a portare il bordo del serbatoio olio in posizione orizzontale.
- Riempire il serbatoio di fluido. (Attenzione! Durante tutta la procedura di spurgo il livello olio nel serbatoio non deve mai scendere sotto il livello MIN.
- Azionare più volte la leva freno per effettuare un parziale riempimento del circuito.
- Inserire un tubo di gomma trasparente sulla vite di spurgo
- Spurgare l'impianto ripetendo quanto segue:
  - Tirare la leva freno completamente e mantenerla in questa posizione.
  - Svitare la vite spurgo e lasciare che l'olio misto ad aria fuoriesca dall'impianto.
  - Serrare delicatamente la vite di spurgo.
  - Ripetere questa serie d'operazioni finché dall'impianto uscirà solamente olio. Ricordiamo di rabboccare il livello olio nel serbatoio in modo che non sceda mai sotto il livello minimo.
- Serrare la vite spurgo alla coppia corretta e riempire definitivamente il serbatoio.

g. Verify that there are no leakages from the various fittings and connections. If the braking system has been bled properly, following the lever dead travel, you will feel the direct action of the fluid without any sponginess; if this is not so, repeat the bleeding procedure.

N.B.: • Brake fluid corrodes paints

- Bleeding will not eliminate completely the air that is present in the braking system; the small residual air bubbles that remain in the braking system will be eliminated automatically during the initial brake applications: this will result in a shorter lever travel and less elastic feeling.

## 10.2. Notes

If the lever seems too elastic following the bleeding procedure, proceed in the following manner:

- Remove one brake pad from a caliper.
- Apply the brakes several times so as to push-out the pistons about 3/4 mm.
- Push back the pistons (avoid damaging the disc and the pistons).
- Put the brake pad back into the caliper.
- Repeat the above steps on the other(s) pad(s) and/or caliper(s).
- Verify whether brake lever travel has improved.

## 11. RUNNING-IN (BURNISH PROCEDURE) WITH STEEL DISCS

- Except for particular instructions for specific friction materials, running-in may be done after 5 laps at average speed; at least 90% of the pad surface must be in contact with the disc surface for running-in to be considered complete.
- Avoid running under power with the brakes applied; this will cause sudden temperature increases which may change the friction characteristics of the pads.
- It is important that after running-in the pads and discs are only used together as a set.

## 12. BRAKING SYSTEM FINAL INSPECTIONS

After running a few laps, it is necessary to carry out the following checks:

- The wheels must rotate freely without any residual torque.
- There must not be any interference between disc and caliper.
- The caliper temperature must not exceed 130 °C (verify through the thermotapes of the caliper see fig. 3).

## 13. BRAKE EXAMINATION FOLLOWING USE

### 13.1. Fittings

Verify that there are no leakages from the various components, connections, or fittings. If a leak is found on one of the fittings, either increase the tightening torque, or replace the defective component.

### 13.2. Steel discs

- The discs must be free from cracks of any kind (either originating from the holes or from the borders) and must not show anomalous wear or scratch marks.
- Thickness of the braking surfaces cannot be reduced by more than 0.4 mm with respect to the original thickness (0.2 + 0.2 mm for each of the two braking surfaces). Defective or excessively worn discs should be changed; keep in mind that when a disc has to be changed, the whole disc-bell assembly must be changed.

g. Verificare che non ci siano perdite nel circuito. Se l'operazione di spurgo è stata effettuata correttamente, non si avvertirà alla leva "l'effetto spugna", indicante la presenza d'aria nell'impianto. In quest'ultimo caso è obbligatorio ripetere le operazioni di spurgo.

N.B.: • Il fluido freni è corrosivo

- Lo spurgo non elimina TUTTA l'aria all'interno del circuito, qualche piccolissima bolla d'aria resterà necessariamente all'interno. Queste bollicine saranno eliminate automaticamente durante la fase di primo utilizzo dei freni, come risultato si noterà un accorciamento della corsa leva.

## 10.2. Note

Qualora non si riesca ad eliminare l'effetto spugna nonostante ripetute procedure di spurgo, effettuare la seguente operazione:

- Rimuovere una pastiglia freno dalla pinza.
- Azionare la leva freno in modo da far uscire di 3/4 mm il pistoncino dalla propria sede.
- Spingere il pistoncino completamente in sede.
- Rimontare la pastiglia.
- Ripetere l'operazione descritta applicandola a tutti i pistoncini.
- Verificare l'effetto di quest'operazione.

## 11. RODAGGIO DISCHI IN ACCIAIO

- Fatta eccezione per alcuni specifici materiali d'attrito, il rodaggio dovrebbe essere terminato dopo circa 5 giri di pista compiuti a velocità media, quando cioè almeno il 90% della superficie del materiale d'attrito è venuto a contatto con il disco.
- Evitate di rodare le pastiglie mantenendo sia l'acceleratore che il freno azionati: così facendo si generano sovratemperature che possono portare a variazioni sostanziali delle caratteristiche del materiale d'attrito.
- È molto importante che, dopo il rodaggio, sia il disco che le pastiglie siano sempre utilizzati insieme.

## 12. CONTROLLO FINALE

Dopo aver percorso alcuni giri di pista, è conveniente effettuare i seguenti controlli.

- La ruota deve poter ruotare liberamente (la coppia residua deve essere quindi minima).
- Non ci deve essere alcun'interferenza tra disco e pinza freno.
- La temperatura della pinza in esercizio non deve superare i 130° centigradi (fate riferimento alle thermo tapes descritte in figura 3).

## 13. ISPEZIONE COMPONENTI DOPO L'USO

### 13.1. Raccordi tubazioni

Verificare che non ci siano perdite dai vari componenti; se ci fosse un trafilaggio dalle guarnizioni dei raccordi provare ad aumentare leggermente il serraggio del bocchettone. Se la perdita persistesse, sostituire il componente.

### 13.2. Dischi in acciaio

- Il disco deve essere assolutamente privo di cricche (siano esse generate dai fori di pulizia pastiglie oppure dal bordo del disco) e non devono presentare alcun consumo anomalo.
- Lo spessore minimo dei dischi in acciaio è di 0,5 mm. inferiore allo spessore di partenza.  
La sostituzione del disco freno comporta necessariamente anche la sostituzione di tutto l'assieme disco/campana.

### 13.3. Pads

#### 13.3.1. Pad wear inspection

Pads for steel discs should not have a friction material thickness lower than 2 mm. MIN.

#### 13.3.2. Abnormal wear

Pads must not show abnormal or uneven wear; the following must be checked:

- Difference in wear between internal and external pads must not exceed 1 mm MAX.
- Pad tangential wear difference must not exceed 1 mm. MAX (see fig. 6).
- Pad radial wear difference must not exceed 1 mm. MAX (see fig. 7). Defective or excessively worn pads must be changed.

Fig. 6



Fig. 7



Fig. 8



#### 13.3.3. Backplate deformation

Backplate flatness error must not exceed 0,2 mm MAX (see fig. 8); in case of excessive backplate flatness error, the pads must be changed.

### 13.4. Residual torque

Verify that the wheels may rotate freely, without residual torque; in case of residual torque, check the pads as indicated in sections 13.3.1. and 13.432. and if it is the case change them.

### 13.3. Pastiglie freno

#### 13.3.1. Controllo consumo pastiglie

Lo spessore del materiale d'attrito non dovrebbe essere inferiore a 2 mm.

#### 13.3.2. Consumo anomalo pastiglie

Le pastiglie devono consumarsi uniformemente, i seguenti controlli devono essere effettuati:

- La differenza dello spessore tra la pastiglia interna e quella esterna non deve essere superiore a 1 mm.
- La differenza tra lo spessore superiore e quello inferiore (tangenziale) non deve essere superiore a 1 mm. (vedi figura 6).
- La differenza tra lo spessore anteriore e quello posteriore (radiale) non deve superare 1 mm. Pastiglie con consumi al di fuori di quanto indicato devono essere sostituite. (vedi figura 7).

#### 13.3.3. Deformazione della piastrina metallica

La planarità della piastrina deve essere contenuta in 0,2 mm. In caso di deformazione superiore la pastiglia deve essere sostituita.

### 13.4. Coppia residua

Verificate che la ruota possa girare liberamente, senza eccessiva coppia residua. In caso questo non succeda, controllate le pastiglie come indicato nei punti 13.3.1 e 13.3.2.

## 14. GENERAL NOTES

### 14.1. Overhauling and replacement MASTER-CYLINDER:

- These must be replaced after 2 racing seasons MAX, or when problems arise; In case of accident, check all the master-cylinder components and replace those that have been damaged; verify that the master-cylinder functions properly even if there are no apparent damages.

### CALIPER FOR STEEL DISCS

- These must be replaced after 2 racing seasons MAX;
- These must be overhauled after 1 racing season MAX; Overhauling must be performed as soon as problems arise.

### 14.2. Miscellaneous

- Cleaning of the master-cylinder and calipers can only be done with water-based detergents; do not use solvents or paint thinners, these could damage the seals and other rubber components.
- During warehousing the inlet and outlet holes should be protected with the appropriate caps.
- Master-cylinder and calipers cannot be disassembled and taken-a part (removing pistons, seals,...).
- Half-caliper union bolts cannot be re-torqued.
- Replacement of components with non-BREMBO parts is not permitted.
- Overhauling of racing products must be carried out exclusively by BREMBO.

## 14. NOTE GENERALI

### 14.1. Revisione e sostituzione componenti POMPA:

- Deve essere sostituita dopo due anni d'utilizzo oppure quando un problema si presenta. In caso d'incidente verificare tutti i componenti e sostituire quelli danneggiati.

### PINZA:

- Deve essere sostituita dopo due anni d'utilizzo oppure quando un problema si presenta.
- Deve essere revisionata dopo un anno d'utilizzo oppure quando un problema si presenta.

### 14.2. Varie

- La pulizia della pompa e della pinza deve essere effettuata con detergenti a base d'acqua, evitando assolutamente l'utilizzo di solventi, trielina o similari, che possono danneggiare seriamente i componenti.
- Durante lo stoccaggio, i fori d'ingresso/uscita olio devono essere tappati.
- Lo smontaggio delle pinze e delle pompe è assolutamente vietato.
- Le viti d'unione delle semipinze non possono essere riserrate.
- L'utilizzo di ricambi non originali non è permesso.
- Le revisioni devono essere effettuate esclusivamente da BREMBO.

Speed



SECTION

1

# Racing Pads (Z04 compound)



*Brembo Racing present its range of high performing racing brake pads. These racing pads are exclusively developed for the highest levels of racing use and have been designed to give top performances in extreme situations. The main features are a high braking control, a more stable system, an increase in braking power, resistance to higher temperature and low wear. The pads are easy to bed.*

***Brembo Racing Z04 compound is used in the world Superbike & Supersport Championships and are now available for Supertock, Motocross and Supermotard applications.***

Brembo Racing presenta la nuova gamma di pastiglie racing ad alte prestazioni. Queste pastiglie sono state sviluppate esclusivamente per le competizioni di alto livello e sono state progettate per offrire il massimo delle prestazioni nelle competizioni più estreme: maggiore controllo della frenata, stabilità dell'impianto, aumento della potenza frenante, resistenza alle alte temperature ed usura ridotta. Sono inoltre facili da rodare.

La mescola Brembo Racing Z04, utilizzata nei Campionati Mondiali Superbike e Supersport, è ora disponibile per applicazioni Superstock, Motocross e Supermotard.



(see application list page 13)

(vedere lista applicazioni a pag. 13)

**Code M478Z04**

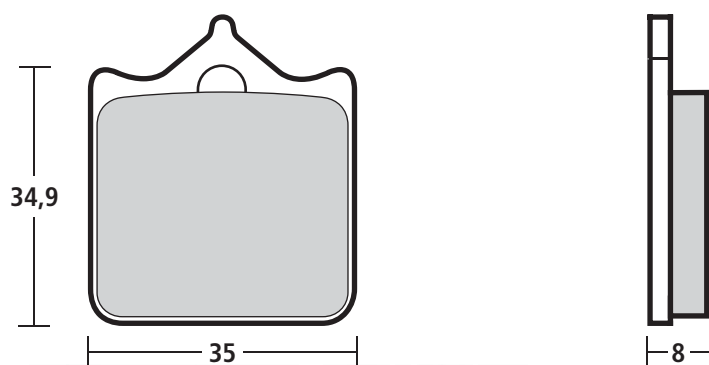

**Code M488Z04**

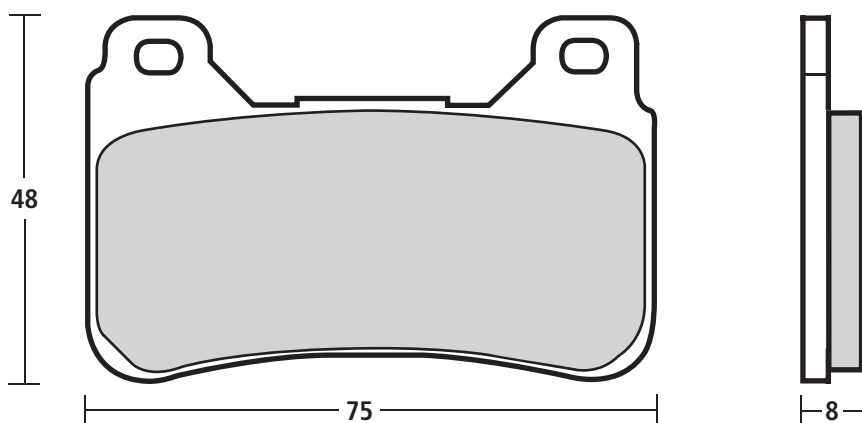

**Code M497Z04**

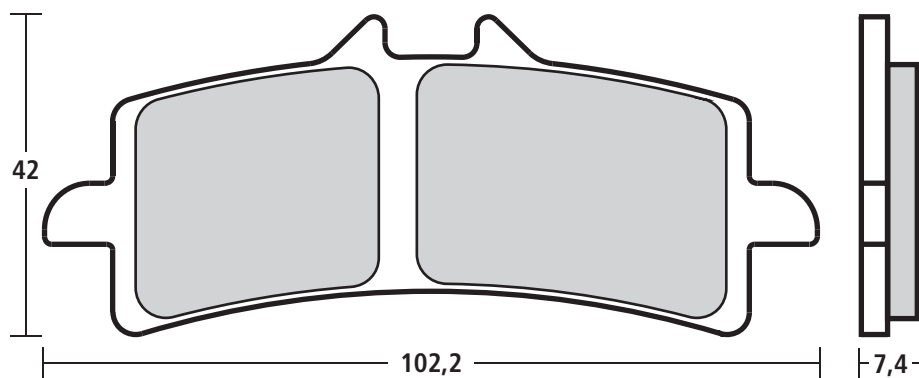

**Code M538Z04**

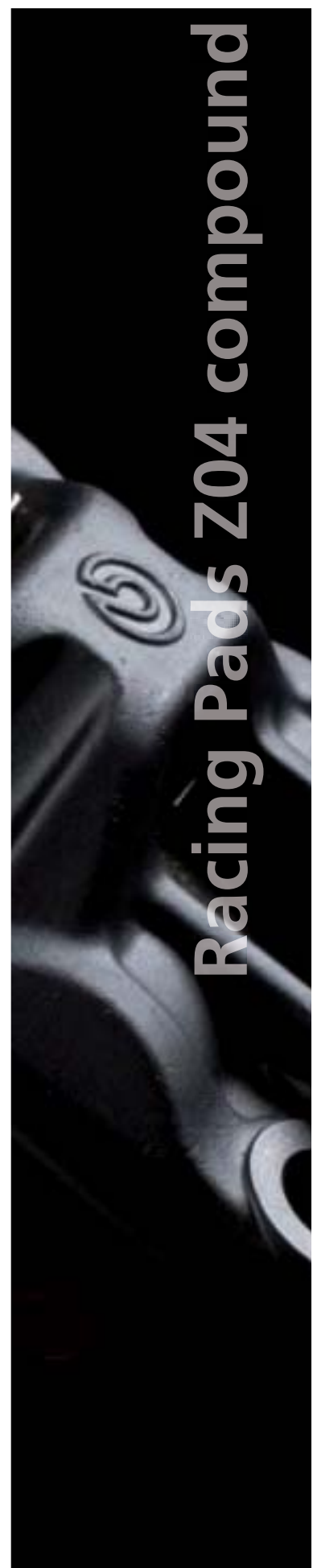
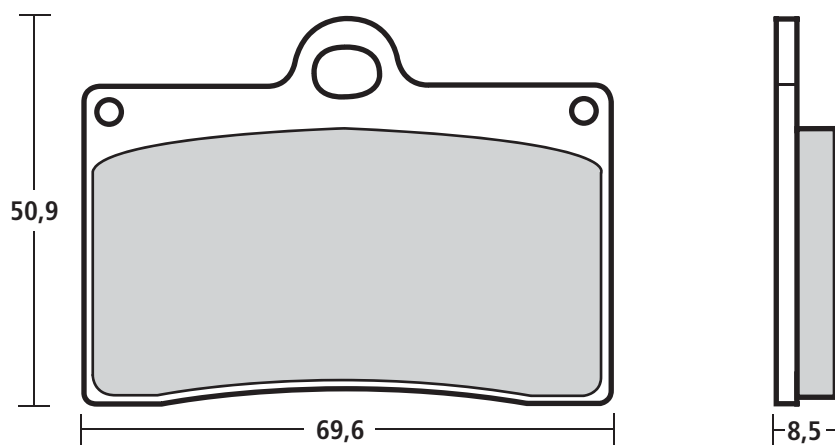

(see application list page 13)

(vedere lista applicazioni a pag. 13)

Code M508Z04

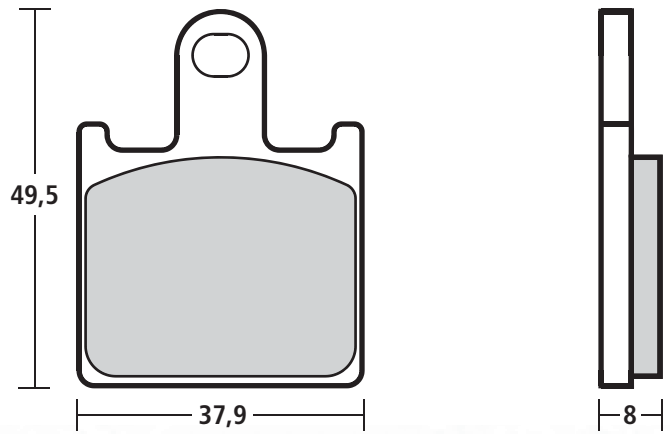

Code M518Z04

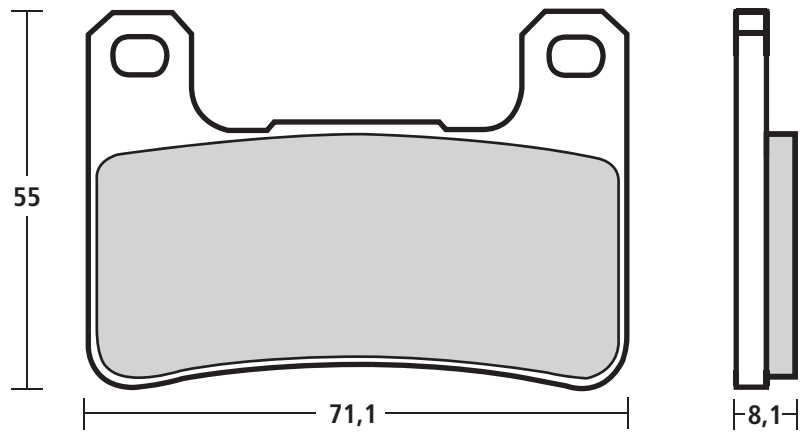

Code M528Z04

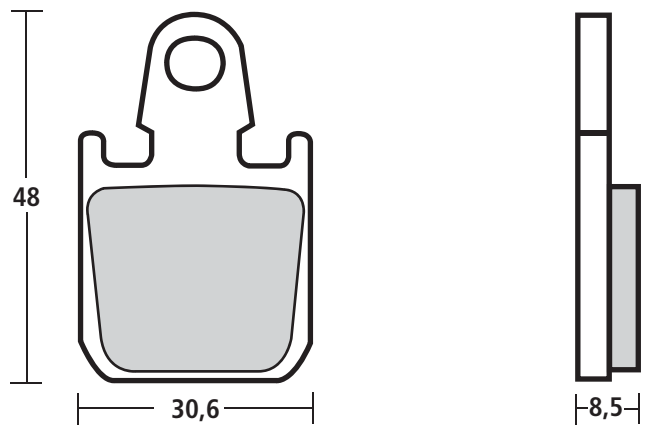
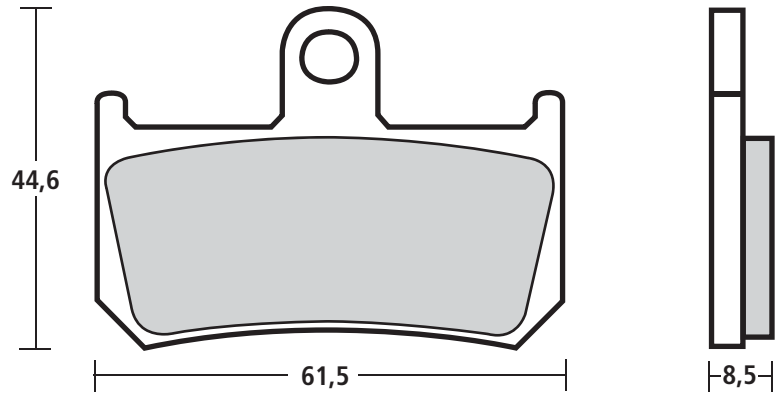

Brand	cc.	Model	Year	Code
<b>Aprilia</b>	1000	RSV FACTORY	04 >	M478Z04
	1000	RSV NERA	04	M478Z04
	1000	RSV R	01-03	M478Z04
	1000	TUONO R	03 >	M478Z04
	1000	TUONO RACING	04	M478Z04
<b>Benelli</b>	449	BX SUPERMOTARD	08	M478Z04
	1130	TNT SPORT	05 >	M478Z04
	1130	TORNADO TRE	06 >	M478Z04
<b>Bimota</b>	1000	DB5	05 >	M478Z04
	1000	DB6 DELIRIO	06 >	M478Z04
	1000	SB8 K	04-06	M478Z04
		SANTAMONICA		
	1098	DB7	08	M478Z04
	1100	DB6 R DELIRIO	08	M478Z04
<b>BMW</b>	1200	HP2 Sport	08	M497Z04
<b>Ducati</b>	748	748R	01-02	M478Z04
	748	749	03-07	M478Z04
	748	749 DARK	05-06	M478Z04
	748	749 R	03-07	M478Z04
	748	749 S	03-07	M478Z04
	992	HYPERMOTARD HM10	06 >	M478Z04
	996	996 R	01	M478Z04
	998	998 F.E.	04	M478Z04
	998	998 R	02	M478Z04
	998	998 S	02	M478Z04
	998	999	03-07	M478Z04
	998	999 R	03-07	M478Z04
	998	999 S	03-07	M478Z04
	998	999 XEROX	06	M478Z04
	990	DESMOSEDICI RR	07 >	M497Z04
		(D16RR)		
	1099	1098	07 >	M497Z04
	1099	1098 S	07 >	M497Z04
	1099	1098 S Tricolore	07 >	M497Z04
	1100	HYPERMOTARD S	07 >	M497Z04
<b>Honda</b>	600	CBR RR	05-06	M488Z04
	600	CBR RR	07 >	M488Z04
	1000	CB R	08 >	M488Z04
	1000	CBR RR	04-05	M488Z04
	1000	CBR RR	06 >	M888Z04
<b>Husqvarna</b>	250	SMR	06 >	M478Z04
	450	SMR	04 >	M478Z04
	450	SMR	06 >	M478Z04
	450	SMR R	06 >	M478Z04
	510	SM CENTENNIAL	06	M478Z04
	510	SMR	05 >	M478Z04
	510	SMR	06 >	M478Z04
	570	SMR	03-04	M478Z04
	610	SM	05	M478Z04
	610	SMS	06	M478Z04

Brand	cc.	Model	Year	Code
<b>Kawasaki</b>	600	ZX-6R	07 >	M508Z04
	1000	ZX 10R	08	M518Z04
<b>KTM</b>	690	DUKE	08	M478Z04
	690	SUPERMOTO PRESTIGE07	>	M478Z04
	690	SMC	08	M478Z04
	950	DUKE	03	M478Z04
	950	SUPERMOTO	05 >	M478Z04
	950	SUPERMOTO	07 >	M478Z04
	990	SUPER DUKE	05	M478Z04
	990	SUPER DUKE	06 >	M478Z04
	990	SUPER DUKE R	07 >	M478Z04
	990	SUPERMOTO	06 >	M478Z04
	1190	RC8	08	M497Z04
<b>Mondial</b>	1000	PIEGA	02	M478Z04
	1000	PIEGA EVO	04	M478Z04
	1000	STARFIGHTER RZ	04	M478Z04
	1000	PIEGA RZ NUDA	04	M478Z04
<b>MV Agusta</b>	910	BRUTALE R	06 >	M478Z04
	1000	F4 R 312	07 >	M478Z04
	1000	F4 R, R 1+1	06 >	M478Z04
	1000	F4 SENNA	06 >	M478Z04
	1078	BRUTALE RR	08	M497Z04
	1078	F4 RR 312	08	M497Z04
<b>Sherco</b>	450	4.5 i SUPERMOTARD	06	M478Z04
<b>Suzuki</b>	600	GSX-R	04-05	M518Z04
	600	GSX-R	06 >	M518Z04
	750	GSX-R	04-05	M518Z04
	750	GSX-R	06 >	M518Z04
	1000	GSX R K4	04	M518Z04
	1000	GSX R K5, K6	05-06	M518Z04
	1000	GSX R K7	07 >	M518Z04
	1300	GSX-R Hayabusa	08	M518Z04
	TM	450 SMX F	03	M478Z04
	660	SMX F	05	M478Z04
	<b>Triumph</b>	1050	SPEED TRIPLE	08
<b>Yamaha</b>	600	YZF THUNDER CAT	96-98	M538Z04
	600	YZF R6	99-02	M538Z04
	600	YZF R6	03 >	M538Z04
	750	YZF R7	99	M538Z04
	1000	YZF THUNDER ACE	96	M538Z04
	1000	YZF R1	98-01	M538Z04
	1000	YZF R1	02-03	M538Z04
	1000	YZF R1	04-06	M538Z04
	1000	YZF R1 SP	06	M538Z04
1000	YZF R1	07 >	M528Z04	



**TECHNICAL  
CHARACTERISTIC**  
**LOW COMPRESSIBILITY FACTOR AT  
HIGH TEMPERATURE**  
**HIGH DRY BOILING POINT**

*Brembo Racing LCF 600 PLUS has been specifically formulated to provide the highest performance under all racing condition.  
Exceeds the requirements of U.S. FMVSS 116 DOT4 specification.*

*Compatible with all Brembo Racing brake systems. Can be mixed with other DOT3 and DOT4 racing brake fluids.  
Anyway we suggest to drain the brake system before filling with Brembo Racing LCF 600 PLUS.*

*Brembo Racing LCF 600 PLUS must not be used in brake system containing magnesium parts.*

**CARATTERISTICHE  
TECNICHE**  
**BASSO FATTORE DI COMPRIMIBILITÀ  
AD ALTE TEMPERATURE**  
**ALTO PUNTO DI EBOLLIZIONE**

Brembo Racing LCF 600 PLUS è stato specificatamente formulato per fornire la più alta prestazione in tutte le condizioni. Oltrepassa le richieste della specifica U.S. FMVSS 116 DOT4.

Compatibile con tutti gli impianti frenanti Brembo. Può essere miscelato con altri fluidi racing DOT3 e DOT4.  
**Si consiglia comunque di svuotare completamente l'impianto dal fluido presente.**

Brembo LCF 600 Plus non deve essere usato in impianti frenanti che contengono parti in magnesio.

*Thermopaints and thermotapes are used to keep the braking system temperatures under control on the track: paints measure the temperature reached by the disk, while thermotapes indicated the caliper temperature. Put the paints on the outer edge, clean and degreased, so as the brake pads do not remove them during the braking. We suggest to apply the colour tapes with 1cm. distance among them. We also recommend to put the paints on two opposite points of the disc to better control the temperature of the whole rotor. Shake the tiny bottles before using, eventually add a few drops of diluent in case the pigment is not fluid enough. Apply two coats of paint and let dry before riding. Thermotapes are to be applied on the pistons area after having cleaned and degreased the surface.*

Le vernici termoviranti e le thermotapes sono utilizzate per monitorare il regime termico dell'impianto frenante in pista: le vernici misurano la temperatura raggiunta dal disco freno mentre le thermotapes quella della pinza. Le vernici termoviranti si applicano sul bordo esterno del disco, sgrassato e pulito. È consigliabile applicare le strisce di colore distanziate tra loro di circa 1 cm. È oltremodo consigliabile applicare le vernici in due punti contrapposti del disco, per meglio controllare la temperatura dell'intera fascia. Agitare i flaconcini prima dell'uso, eventualmente aggiungere poche gocce di diluente nel caso il pigmento si presenti poco fluido. Applicare due strati di vernice e lasciare asciugare prima di utilizzare la moto. Le thermotapes si applicano nella zona dei pistoncini, dopo avere sgrassato e pulito dove si intende incollarle.



Code	Description	Range
02516811	Thermo tapes / Bande termosensibili	88 / 127 °C.
02516812	Thermo tapes / Bande termosensibili	132 / 171 °C.
02571120	Thermal paints / Vernici termoviranti	See below / Vedi sotto

Paint color Colore vernice	Change Temperature Temperature di viraggio	Color after change Colore dopo il viraggio
Violet / Viola	~ 370 °C.	White / Bianco
Green / Verde	~ 430 °C.	White / Bianco
Orange / Arancio	~ 560 °C.	Yellow / Giallo
Red / Rosso	~ 630 °C.	White / Bianco

1

# 108 mm Radial Monobloc Caliper Kit P4 34 Code 220A39710

## Spare Parts • Ricambi

Spring / Molletta  
120225579

Bleeding screw / Vite spurgo  
105338752



## Technical Characteristics • Caratteristiche Tecniche

Pistons / Pistoni Ø	34 mm.
Construction Material / Materiale	Casting Aluminium / Alluminio fuso
Finishing / Finissaggio	Brilliant Anodic Oxidation / Anod. Brillante
Weight (with pads) / Massa (con pastiglie)	1000 gr.
Brake Fluid / Fluido freni	DOT 4
Hardware / Viteria	Steel / Acciaio
Pistons / Pistoni	Aluminium / Alluminio
Center to center / Interasse	108 mm.
Offset / Offset	22,5 mm.

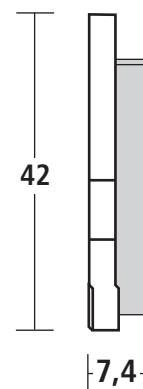
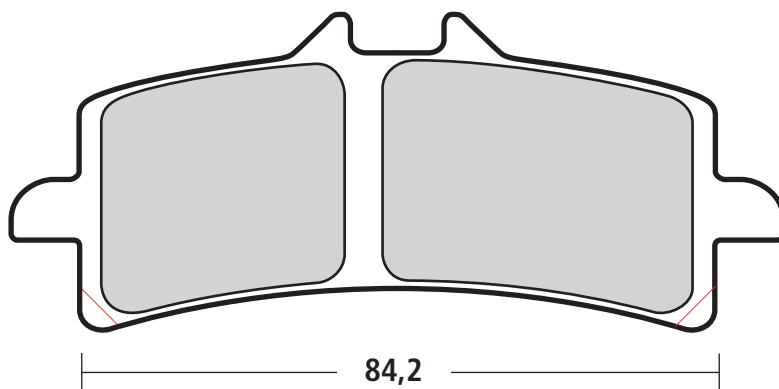

## Pads • Pastiglie

Code	Performance	Life
107988210	•	•
Genuine		
07BB3050	•	•
Genuine		

## Pads • Pastiglie

Code	Performance	Life
07BB30RC	+	•
RC Compound		
M497Z04	++	+
Z04 Compound		

# 100 mm Radial Monobloc Caliper Kit P4 34 Code 220988530

## Spare Parts • Ricambi

Spring / Molletta  
120225579

Bleeding screw / Vite spurgo  
105338752



## Technical Characteristics • Caratteristiche Tecniche

Pistons / Pistoni Ø	34 mm.
Construction Material / Materiale	Casting Aluminium / Alluminio fuso
Finishing / Finissaggio	Brilliant Anodic Oxidation / Anod. Brillante
Weight (with pads) / Massa (con pastiglie)	1015 gr.
Brake Fluid / Fluido freni	DOT 4
Hardware / Viteria	Steel / Acciaio
Pistons / Pistoni	Aluminium / Alluminio
Center to center / Interasse	100 mm.
Offset / Offset	30 mm.

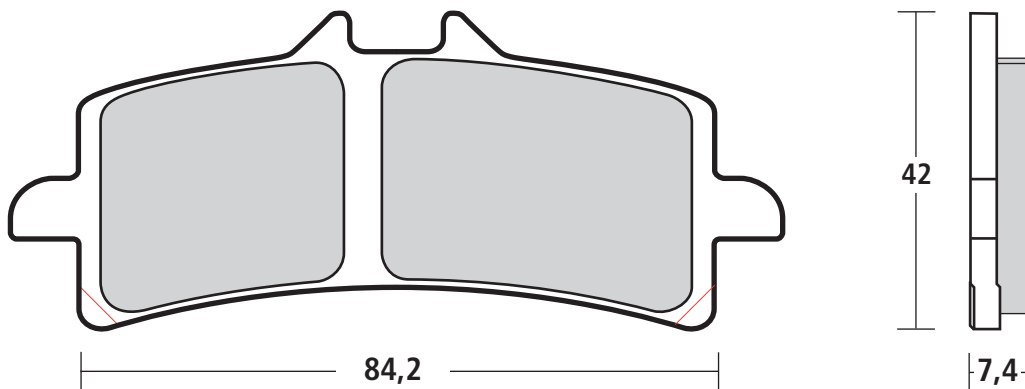

## Pads • Pastiglie

Code	Performance	Life
107988210	•	•
Genuine		
07BB3050	•	•
Genuine		

## Pads • Pastiglie

Code	Performance	Life
07BB30RC	+	•
RC Compound		
M497Z04	++	•
Z04 Compound		

1

# 108 mm Radial CNC Caliper Kit P4 30/34

**Code 220A01610** (hard anodized)

**Code 220A80210** (nickel coating)

## Spare Parts • Ricambi

Spindle / Perno

120394230

Spring / Molletta

120225590

Bleeding screw / Vite spurgo

105281228

Pin / Copiglia

105454218



## Technical Characteristics • Caratteristiche Tecniche

Pistons / Pistoni Ø	30 / 34 mm.
Construction Material / Materiale	CNC Aluminium / Alluminio CNC
Finishing / Finissaggio	Hard anod. - Nick. coat. / Anod. dura - Nichelata
Weight (with pads) / Massa (con pastiglie)	1030 gr.
Brake Fluid / Fluido freni	DOT 4
Hardware / Viteria	Steel / Acciaio
Pistons / Pistoni	Aluminium / Alluminio
Center to center / Interasse	108 mm.
Offset / Offset	22,5 mm.

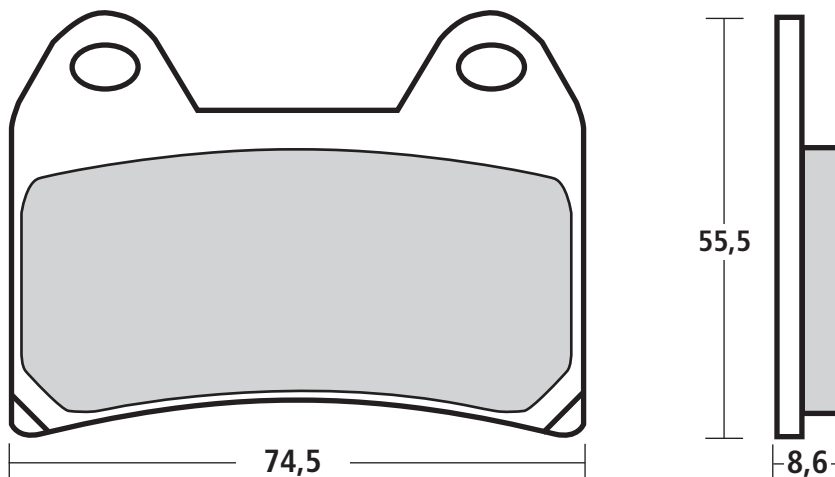

## Pads • Pastiglie

Code	Performance	Life
107670821	•	•
Genuine		
07BB1950	•	•
Genuine		

## Pads • Pastiglie

Code	Performance	Life
07BB19RC	+	•
RC Compound		
107670823	++	•
Z04 Compound		

# 100 mm Radial CNC Caliper Kit P4 30/34

**Code 220A16810** (hard anodized)

**Code 220A80310** (nickel coating)



## Spare Parts • Ricambi

Spindle / Perno  
120394230

Spring / Molletta  
120225590

Bleeding screw / Vite spurgo  
05281228

Pin / Copiglia  
105454218

## Technical Characteristics • Caratteristiche Tecniche

Pistons / Pistoni Ø	30 / 34 mm.
Construction Material / Materiale	CNC Aluminium / Alluminio CNC
Finishing / Finissaggio	Hard anod. - Nick. coat. / Anod. dura - Nichelata
Weight (with pads) / Massa (con pastiglie)	1030 gr.
Brake Fluid / Fluido freni	DOT 4
Hardware / Viteria	Steel / Acciaio
Pistons / Pistoni	Aluminium / Alluminio
Center to center / Interasse	100 mm.
Offset / Offset	30 mm.

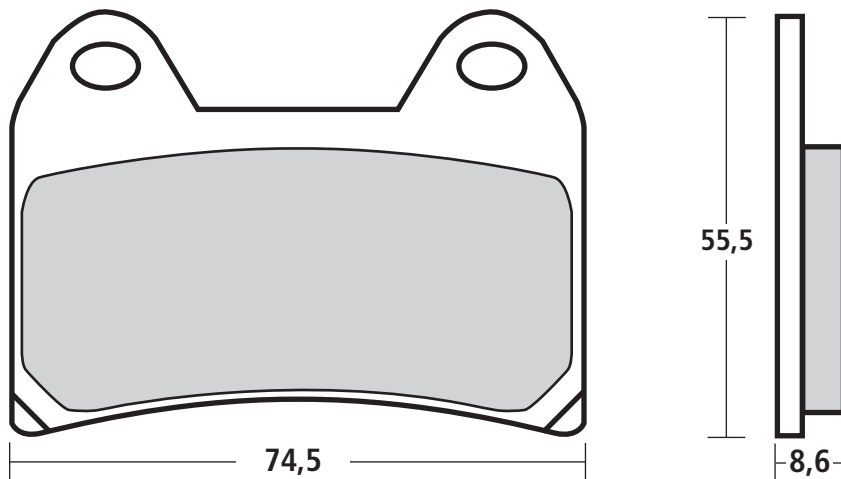

## Pads • Pastiglie

Code	Performance	Life
107670821	•	•
Genuine		
07BB1950	•	•
Genuine		

## Pads • Pastiglie

Code	Performance	Life
07BB19RC	+	•
RC Compound		
107670823	++	•
Z04 Compound		

1

**Yamaha R1 '07/'10  
Radial CNC Caliper Kit  
P4 30/34  
Code 220A16820**

**Spare Parts • Ricambi**

Spindle / Perno  
120394230

Spring / Molletta  
120225590

Bleeding screw / Vite spurgo  
05281228

Pin / Copiglia  
105454218



Caliper supplied with disassembled adaptor

**Technical Characteristics • Caratteristiche Tecniche**

Pistons / Pistoni Ø	30 / 34 mm.
Construction Material / Materiale	CNC Aluminium / Alluminio CNC
Finishing / Finissaggio	Hard anodizing / Anodizzazione dura
Weight (with pads) / Massa (con pastiglie)	1250 gr.
Brake Fluid / Fluido freni	DOT 4
Hardware / Viteria	Steel / Acciaio
Pistons / Pistoni	Aluminium / Alluminio
Center to center / Interasse	As original / Come originale
Offset / Offset	As original / Come originale

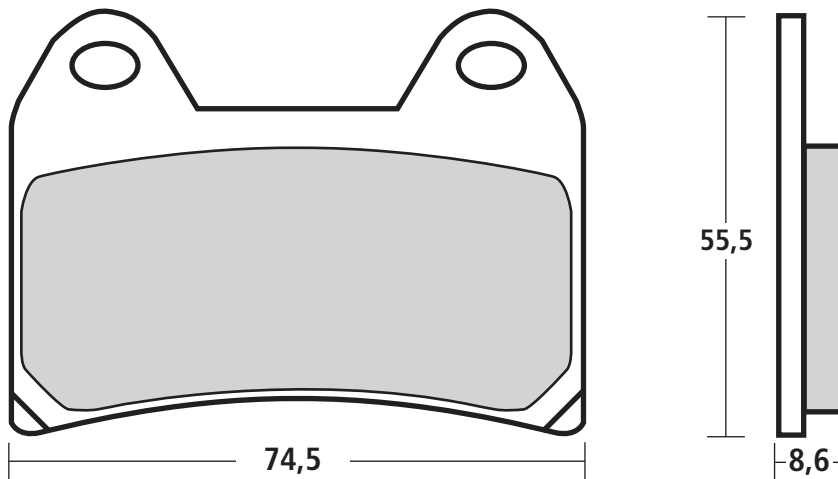

**Pads • Pastiglie**

Code	Performance	Life
107670821	•	•
Genuine		
07BB1950	•	•
Genuine		

**Pads • Pastiglie**

Code	Performance	Life
07BB19RC	+	•
RC Compound		
107670823	++	•
Z04 Compound		

## Radial CNC Caliper P4 32/36 Code XA3B860/61

1

### Spare Parts • Ricambi

Spindle / Perno

20696450

Pin / Copiglia

05454232

Bleeding screw / Vite spurgo

05281213



### Technical Characteristics • Caratteristiche Tecniche

Pistons / Pistoni Ø	32 / 36 mm.
Construction Material / Materiale	CNC Aluminium / Alluminio CNC
Finishing / Finissaggio	Hard anodizing / Anodizzazione dura
Weight (without pads) / Massa (senza pastiglie)	659 gr.
Brake Fluid / Fluido freni	DOT 4
Hardware / Viteria	Steel / Acciaio
Pistons / Pistoni	Aluminium / Alluminio
Center to center / Interasse	108 mm.
Offset / Offset	22,5 mm.

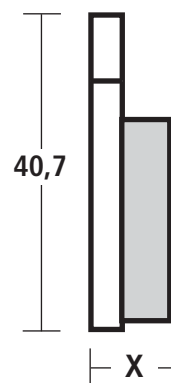
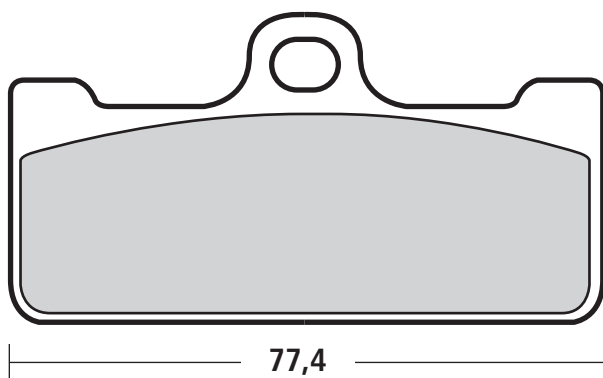

### Pads • Pastiglie

Code	Performance	Life
107684830 Z01 Th. = 8,4	•	•
M028Z04 Z04 Th. = 8	+	•

1

## Radial CNC Caliper P4 32/36 Code XA3B830/31

### Spare Parts • Ricambi

Spindle / Perno

20696410

Pin / Copiglia

05454221

Bleeding screw / Vite spurgo

05281213



### Technical Characteristics • Caratteristiche Tecniche

Pistons / Pistoni Ø	32 / 36 mm.
Construction Material / Materiale	CNC Aluminium / Alluminio CNC
Finishing / Finissaggio	Hard anodizing / Anodizzazione dura
Weight (without pads) / Massa (senza pastiglie)	600 gr.
Brake Fluid / Fluido freni	DOT 4
Hardware / Viteria	Titanium / Titanio
Pistons / Pistoni	Titanium / Titanio
Center to center / Interasse	108 mm.
Offset / Offset	22,5 mm.

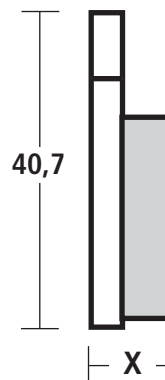
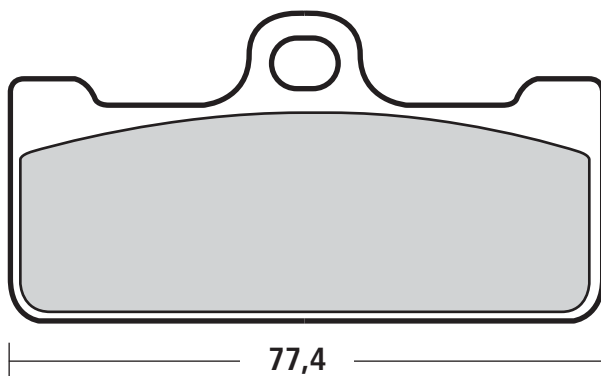

### Pads • Pastiglie

Code	Performance	Life
107684830	•	•
Z01 Th. = 8,4		
M028Z04	+	•
Z04 Th. = 8,0		

# Radial CNC Caliper GP4 RX Code 220B01010



## Spare Parts • Ricambi

Spring / Molletta  
120225579

Bleeding screw / Vite spurgo  
05281228

## Technical Characteristics • Caratteristiche Tecniche

Pistons / Pistoni Ø	32 mm.
Construction Material / Materiale	CNC Aluminium / Alluminio CNC
Finishing / Finissaggio	Nichel coating / Nichelata
Weight (without pads) / Massa (senza pastiglie)	1000 gr.
Brake Fluid / Fluido freni	DOT 4
Hardware / Viteria	Steel / Acciaio
Pistons / Pistoni	Aluminium / Alluminio
Center to center / Interasse	108 mm.
Offset / Offset	22,5 mm.

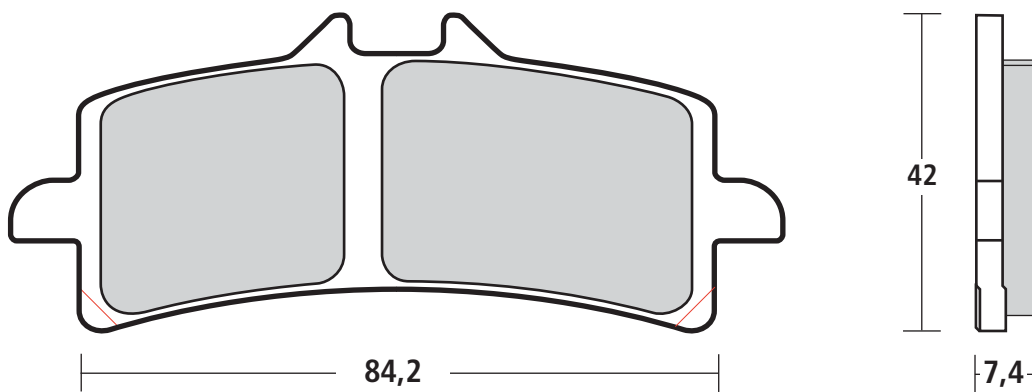

## Pads • Pastiglie

Code	Performance	Life
107988210	•	•
Genuine		
07BB3050	•	•
Genuine		

## Pads • Pastiglie

Code	Performance	Life
07BB30RC	+	•
RC Compound		
M497Z04	++	+
Z04 Compound		

1

# Radial CNC Monobloc Caliper P4 32/36 Code X973760/61

## Spare Parts • Ricambi

Spindle / Perno  
X101708

Pin / Copiglia  
0545221

Bleeding screw / Vite spurgo  
05281213



## Technical Characteristics • Caratteristiche Tecniche

Pistons / Pistoni Ø	32 / 36 mm.
Construction Material / Materiale	CNC Aluminium / Alluminio CNC
Finishing / Finissaggio	Hard anodizing / Anodizzazione dura
Weight (without pads) / Massa (senza pastiglie)	649 gr.
Brake Fluid / Fluido freni	DOT 4
Hardware / Viteria	Titanium / Titanio
Pistons / Pistoni	Titanium / Titanio
Center to center / Interasse	108 mm.
Offset / Offset	22,5 mm.

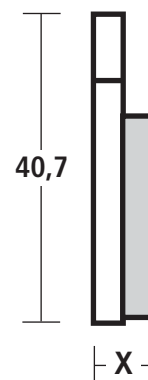
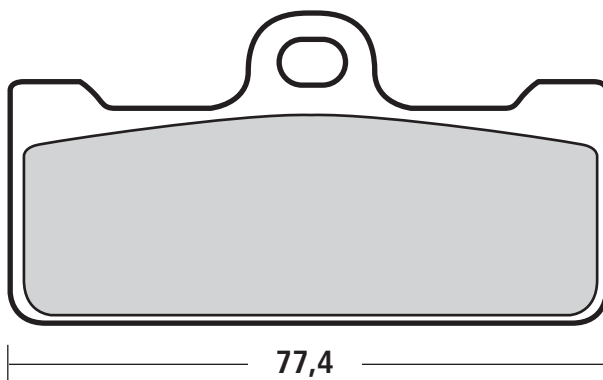

## Pads • Pastiglie

Code	Performance	Life
107684820 Z01 Th. = 8,35	•	•
M029Z04 Z04 Th. = 8	+	•

# Radial Endurance CNC Monobloc Caliper P4 32/36 Code X973780/81

## Spare Parts • Ricambi

Spindle / Perno  
**X101708**

Pin / Copiglia  
**05454221**

Bleeding screw / Vite spurgo  
**05281213**



## Technical Characteristics • Caratteristiche Tecniche

Pistons / Pistoni Ø	32 / 36 mm.
Construction Material / Materiale	CNC Aluminium / Alluminio CNC
Finishing / Finissaggio	Hard anodizing / Anodizzazione dura
Weight (without pads) / Massa (senza pastiglie)	758 gr.
Brake Fluid / Fluido freni	DOT 4
Hardware / Viteria	Titanium / Titanio
Pistons / Pistoni	Titanium / Titanio
Center to center / Interasse	108 mm.
Offset / Offset	22,5 mm.

Caliper specific for Endurance races, equipped with particular pistons radiators and plates for brake pad retain during the quick wheel changes.

Pinza specifica per gare Endurance, dispone di particolari radiatori pistoni e di piastine per il ritegno delle pastiglie durante i cambi ruota.

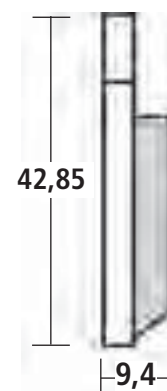
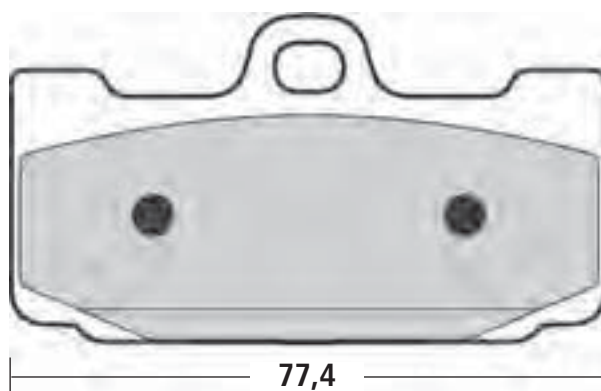

## Pads • Pastiglie

Code	Performance	Life
107684612	•	•
Z03		

1

**Monobloc CNC  
Radial Caliper  
YAMAHA 2007/2010  
Code XA8Y310/11**

**Spare Parts • Ricambi**

Bleeding screw / Vite spurgo  
105281221



**Technical Characteristics • Caratteristiche Tecniche**

<i>Pistons / Pistoni Ø</i>	34 / 38 mm.
<i>Construction Material / Materiale</i>	CNC Aluminium / Alluminio CNC
<i>Finishing / Finissaggio</i>	Hard anodizing / Anodizzazione dura
<i>Weight (without pads) / Massa (senza pastiglie)</i>	840 gr.
<i>Brake Fluid / Fluido freni</i>	DOT 4
<i>Hardware / Viteria</i>	Titanium / Titanio
<i>Pistons / Pistoni</i>	Titanium / Titanio
<i>Center to center / Interasse</i>	As original / Come originale
<i>Offset / Offset</i>	As original / Come originale

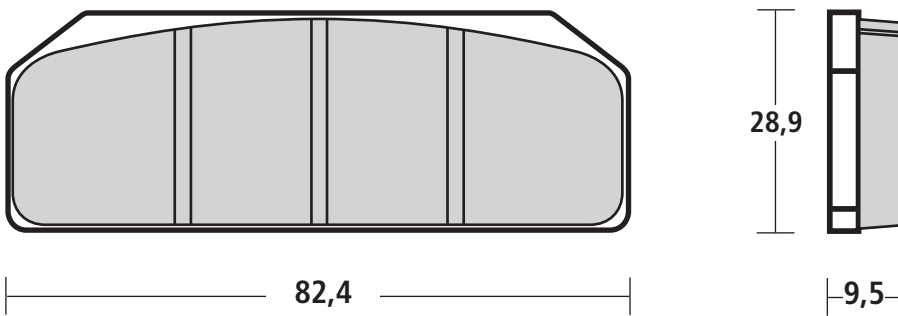

**Pads • Pastiglie**

Code	Performance	Life
07835424	•	•
Z04		

**100 mm CNC Monobloc  
Radial Caliper P4 32/36**  
Code XA7G240/41 (nickel coating)  
Code XA7G210/11 (hard anodized)

1



**Spare Parts • Ricambi**

Bleeding screw cover /  
Cappuccio vite spurgo  
05150220

Bleeding screw / Vite spurgo  
05281221

**Technical Characteristics • Caratteristiche Tecniche**

Pistons / Pistoni Ø	32 / 36 mm.
Construction Material / Materiale	CNC Aluminium / Alluminio CNC
Finishing / Finissaggio	Hard anod. - Nick. coat. / Anod. dura - Nichelata
Weight (with pads) / Massa (con pastiglie)	920 gr.
Brake Fluid / Fluido freni	DOT 4
Hardware / Viteria	Titanium / Titanio
Pistons / Pistoni	Titanium / Titanio
Center to center / Interasse	100 mm.
Offset / Offset	30 mm.

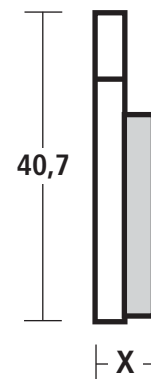
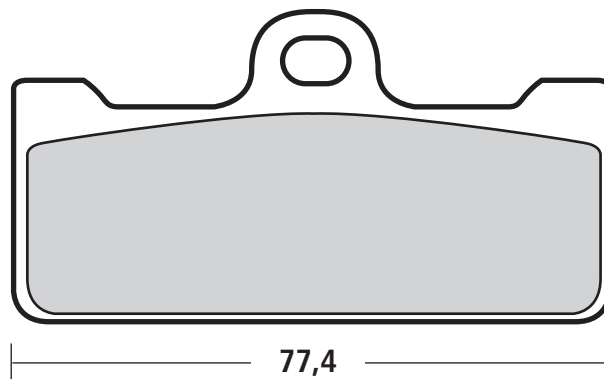

**Pads • Pastiglie**

Code	Performance	Life
107684820 Z01 Th = 8,35	•	•
M028Z04 Z04 Th = 8	+	•

1

## Radial CNC Monobloc Caliper P4 34 Code X99C460/61

### Spare Parts • Ricambi

Spindle / Perno

X99C403

Pin / Copiglia

05454217

Spring / Molletta

X99C416

Bleeding screw / Vite spurgo

05281213



### Technical Characteristics • Caratteristiche Tecniche

Pistons / Pistoni Ø	34 mm.
Construction Material / Materiale	CNC Aluminium / Alluminio CNC
Finishing / Finissaggio	Hard anodizing / Anodizzazione dura
Weight (without pads) / Massa (senza pastiglie)	660 gr.
Brake Fluid / Fluido freni	DOT 4
Hardware / Viteria	Titanium / Titanio
Pistons / Pistoni	Titanium / Titanio
Center to center / Interasse	108 mm.
Offset / Offset	22,5 mm.

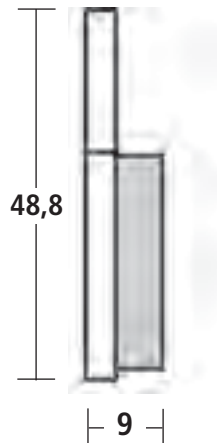

### Pads • Pastiglie

Code	Performance	Life
M049Z04	•	•
Z04		

# Radial CNC Monobloc Caliper GP4 RR Code XA93310/11

## Spare Parts • Ricambi

Bleeding screw / Vite spurgo  
05281233



## Technical Characteristics • Caratteristiche Tecniche

<i>Pistons / Pistoni Ø</i>	32 / 36 mm.
<i>Construction Material / Materiale</i>	CNC Aluminium / Alluminio CNC
<i>Finishing / Finissaggio</i>	Nichel coating / Nichelata
<i>Weight (without pads) / Massa (senza pastiglie)</i>	578 gr.
<i>Brake Fluid / Fluido freni</i>	DOT 4
<i>Hardware / Viteria</i>	Titanium / Titanio
<i>Pistons / Pistoni</i>	Titanium / Titanio
<i>Center to center / Interasse</i>	108 mm.
<i>Offset / Offset</i>	22,5 mm.

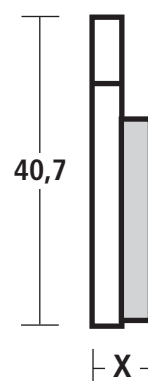
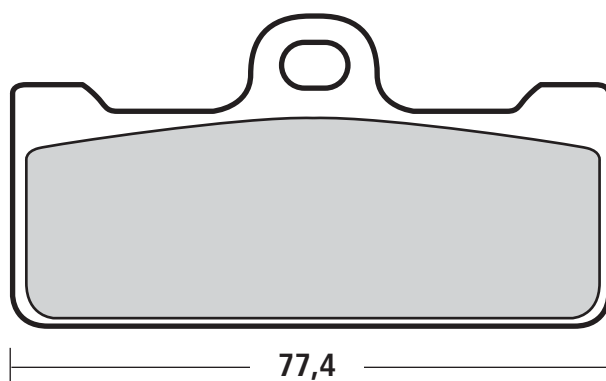

## Pads • Pastiglie

Code	Performance	Life
107684820 Z01 Th = 8,35	•	•
M028Z04 Z04 Th = 8	+	•

1

# Monobloc CNC Caliper P4 32/36 Code X101740/41

## Spare Parts • Ricambi

Spindle / Perno  
X101708

Pin / Copiglia  
05454221

Bleeding screw / Vite spurgo  
X101739



## Technical Characteristics • Caratteristiche Tecniche

Pistons / Pistoni Ø	32 / 36 mm.
Construction Material / Materiale	CNC Aluminium / Alluminio CNC
Finishing / Finissaggio	Hard anodizing / Anodizzazione dura
Weight (without pads) / Massa (senza pastiglie)	660 gr.
Brake Fluid / Fluido freni	DOT 4
Hardware / Viteria	Titanium / Titanio
Pistons / Pistoni	Titanium / Titanio
Center to center / Interasse	40 mm.
Offset / Offset	26,5 mm.

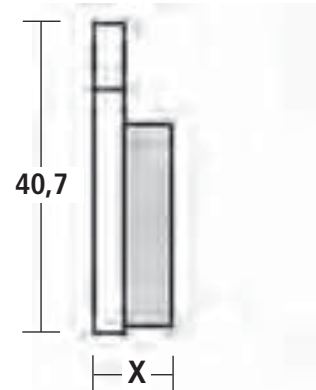
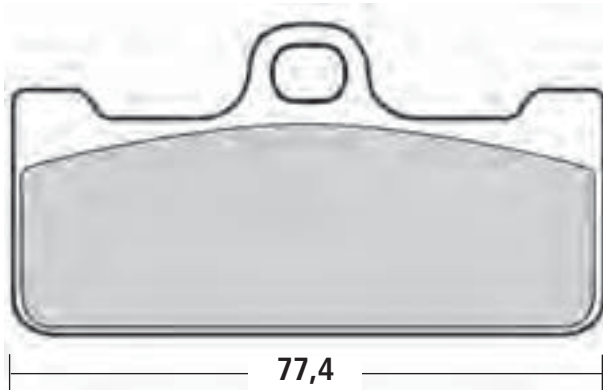

## Pads • Pastiglie

Code	Performance	Life
107684820 Z01 Th = 8,35	•	•
M028Z04 Z04 Th = 8	+	•

## SuperSport CNC Rear Caliper P2 34 Code 120A44110



### Spare Parts • Ricambi

Spindle / Perno  
120A44170

Bleeding screw / Vite spurgo  
105338752

### Technical Characteristics • Caratteristiche Tecniche

Pistons / Pistoni Ø	34 mm.
Construction Material / Materiale	CNC Aluminium / Alluminio CNC
Finishing / Finissaggio	Hard anodizing / Anodizzazione dura
Weight (with pads) / Massa (con pastiglie)	581 gr.
Brake Fluid / Fluido freni	DOT 4
Hardware / Viteria	Steel / Acciaio
Pistons / Pistoni	Aluminium / Alluminio
Center to center / Interasse	84 mm.
Offset / Offset	10 mm.

With specific support for Supersport Motorcycle. Pinza specifica completa di supporto.

120A44111 (Honda CBR 1000 '08) Marchesini Wheels only  
 120A44112 (Suzuki GSXR 1000 '07/'09)  
 120A44113 (Kawasaki ZX10R '08) Marchesini Wheels only  
 120A44114 (Yamaha R1 '06/'09)

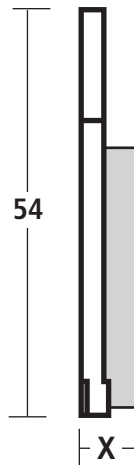
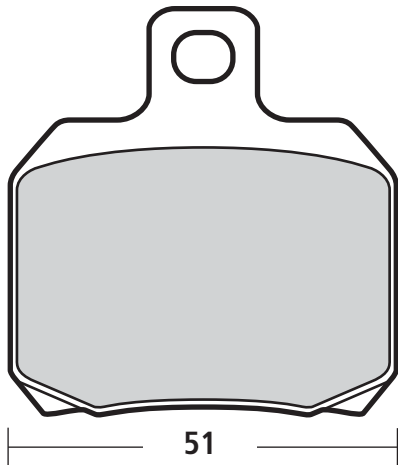

### Pads • Pastiglie

Code	Performance	Life
07BB2010	•	•
07BB2050	+	•
Sintered		

1

## Rear CNC Caliper P2 24 Code 206001

### Spare Parts • Ricambi

Spring / Molletta  
X206007

Bleeding screw / Vite spurgo  
X101739



### Technical Characteristics • Caratteristiche Tecniche

Pistons / Pistoni Ø	24 mm.
Construction Material / Materiale	CNC Aluminium / Alluminio CNC
Finishing / Finissaggio	Hard anodizing / Anodizzazione dura
Weight (with pads) / Massa (con pastiglie)	198 gr.
Brake Fluid / Fluido freni	DOT 4
Hardware / Viteria	Titanium / Titanio
Pistons / Pistoni	Titanium / Titanio
Center to center / Interasse	64 mm.
Offset / Offset	16,5 mm.

To be used with 24 mm. rotor brake disc height.  
Pastiglia da utilizzare con fascia frenante h = 24 mm.

To be used with 30 mm. rotor brake disc height.  
Pastiglia da utilizzare con fascia frenante h = 30 mm.

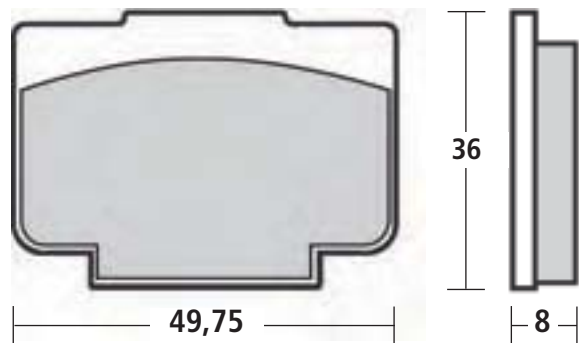
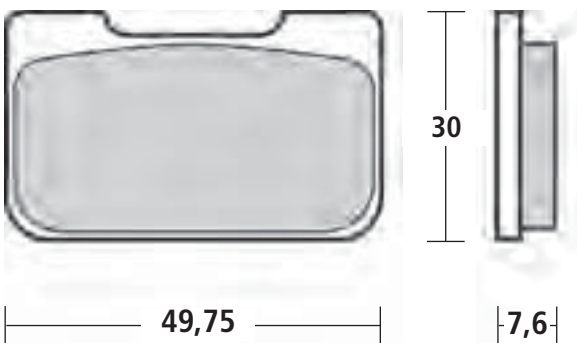

### Pads • Pastiglie

Code	Performance	Life
07934090	•	•
206022	++	+
Sintered		

## Rear CNC Caliper P4 24 Code 206101

### Spare Parts • Ricambi

Spring / Molletta  
X206007

Bleeding screw / Vite spurgo  
X101739



### Technical Characteristics • Caratteristiche Tecniche

Pistons / Pistoni Ø	24 mm.
Construction Material / Materiale	CNC Aluminium / Alluminio CNC
Finishing / Finissaggio	Hard anodizing / Anodizzazione dura
Weight (with pads) / Massa (con pastiglie)	262 gr.
Brake Fluid / Fluido freni	DOT 4
Hardware / Viteria	Titanium / Titanio
Pistons / Pistoni	Titanium / Titanio
Center to center / Interasse	64 mm.
Offset / Offset	16,5 mm.

To be used with 24 mm. rotor brake disc height.  
Pastiglia da utilizzare con fascia frenante h = 24 mm.

To be used with 30 mm. rotor brake disc height.  
Pastiglia da utilizzare con fascia frenante h = 30 mm.

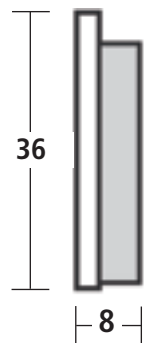
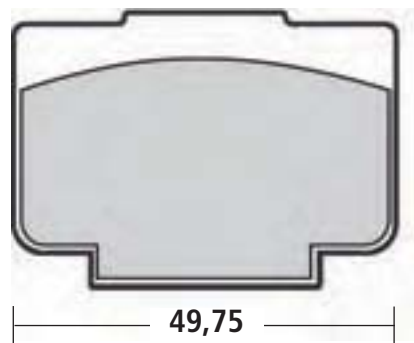
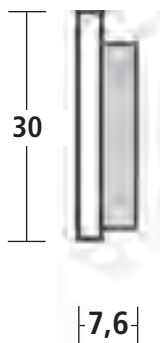

### Pads • Pastiglie

Code	Performance	Life
07934020	•	•
X988831	+	•
Sintered		
X988822	++	•
Sintered		

### Pads • Pastiglie

Code	Performance	Life
07934010	•	•
X988802	++	+
Sintered		

1

# Rear CNC Caliper P4 24 (for rear ventilated disc) Code 206121



## Spare Parts • Ricambi

Spring / Molletta  
X206007

Bleeding screw / Vite spurgo  
X101739

## Technical Characteristics • Caratteristiche Tecniche

Pistons / Pistoni Ø	24 mm.
Construction Material / Materiale	CNC Aluminium / Alluminio CNC
Finishing / Finissaggio	Hard anodizing / Anodizzazione dura
Weight (with pads) / Massa (con pastiglie)	262 gr.
Brake Fluid / Fluido freni	DOT 4
Hardware / Viteria	Titanium / Titanio
Pistons / Pistoni	Titanium / Titanio
Center to center / Interasse	64 mm.
Offset / Offset	18,5 mm.

To be used with 24 mm. rotor brake disc height.  
Pastiglia da utilizzare con fascia frenante h = 24 mm.

To be used with 30 mm. rotor brake disc height.  
Pastiglia da utilizzare con fascia frenante h = 30 mm.

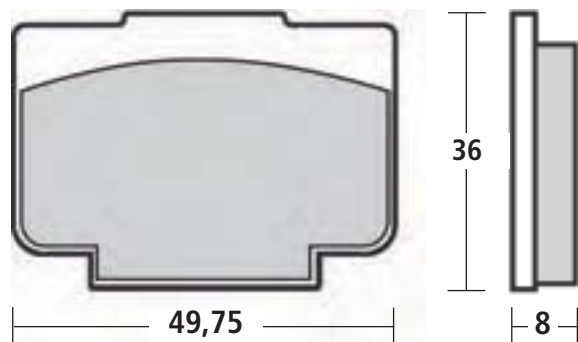
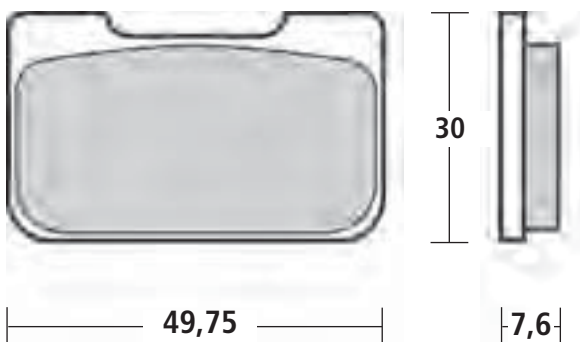

## Pads • Pastiglie

Code	Performance	Life
07934020	•	•
X988831	+	•
Sintered		
X988822	++	•
Sintered		

## Pads • Pastiglie

Code	Performance	Life
07934010	•	•
X988832	++	•
Sintered		

## Rear CNC Caliper P2 34 Code X988870



### Spare Parts • Ricambi

Spindle / Perno  
X988815

Spring / Molletta  
X988818

Bleeding screw / Vite spurgo  
X101739

### Technical Characteristics • Caratteristiche Tecniche

Pistons / Pistoni Ø	34 mm.
Construction Material / Materiale	CNC Aluminium / Alluminio CNC
Finishing / Finissaggio	Hard anodizing / Anodizzazione dura
Weight (with pads) / Massa (con pastiglie)	394 gr.
Brake Fluid / Fluido freni	DOT 4
Hardware / Viteria	Titanium / Titanio
Pistons / Pistoni	Titanium / Titanio
Center to center / Interasse	64 mm.
Offset / Offset	16,5 mm.

To be used with 24 mm. rotor brake disc height.  
Pastiglia da utilizzare con fascia frenante h = 24 mm.

To be used with 30 mm. rotor brake disc height.  
Pastiglia da utilizzare con fascia frenante h = 30 mm.

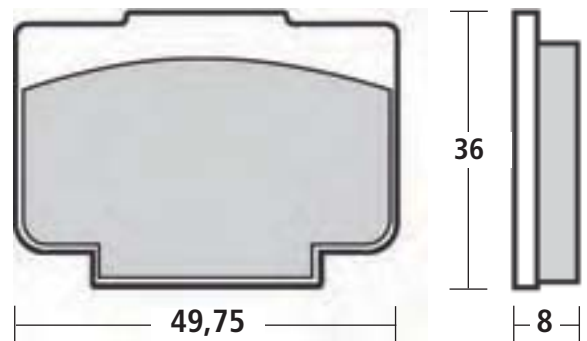
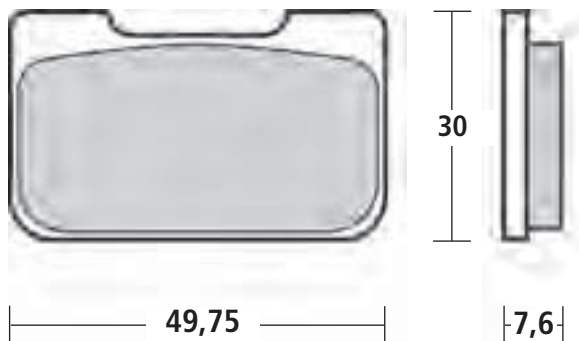

### Pads • Pastiglie

Code	Performance	Life
07934020	•	•
X988831	+	•
Sintered		
X988822	++	•
Sintered		

### Pads • Pastiglie

Code	Performance	Life
07934010	•	•
X988802	++	•
Sintered		

1

## Rear CNC Caliper P2 30 Code XA1J040

### Spare Parts • Ricambi

Spindle / Perno

**XA1J009**

Pin / Copiglia

**05454217**

Spring / Molletta

**XA1J046**

Bleeding screw / Vite spurgo

**101739**



### Technical Characteristics • Caratteristiche Tecniche

Pistons / Pistoni Ø	30 mm.
Construction Material / Materiale	CNC Aluminium / Alluminio CNC
Finishing / Finissaggio	Hard anodizing / Anodizzazione dura
Weight (with pads) / Massa (con pastiglie)	348 gr.
Brake Fluid / Fluido freni	DOT 4
Hardware / Viteria	Titanium / Titanio
Pistons / Pistoni	Titanium / Titanio
Center to center / Interasse	64 mm.
Offset / Offset	16,5 mm.

To be used with 24 mm. rotor brake disc height.  
Pastiglia da utilizzare con fascia frenante h = 24 mm.

To be used with 30 mm. rotor brake disc height.  
Pastiglia da utilizzare con fascia frenante h = 30 mm.

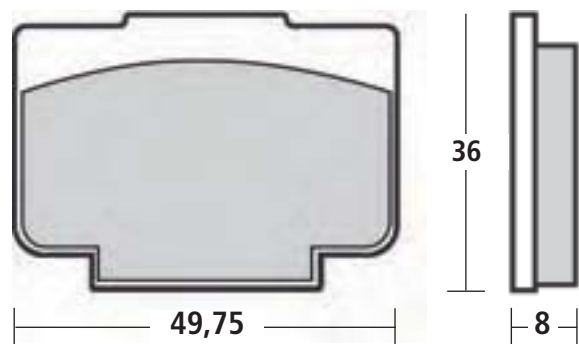
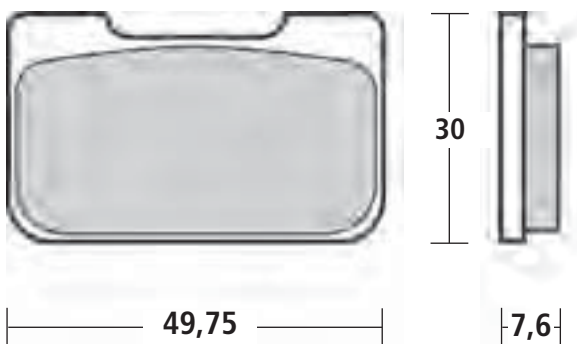

### Pads • Pastiglie

Code	Performance	Life
07934020	•	•
X988831	+	•
Sintered		
X988822	++	•
Sintered		

### Pads • Pastiglie

Code	Performance	Life
07934010	•	•
X988802	++	•
Sintered		

## Adjustable (RCS) Radial Master Cylinder

The RCS device consists into an eccentric drive that allows to select the pump lever ratio between 18 and 20 mm, to obtain the ideal feeling among the rider, his driving style, the bike and the course: simply selecting the lever ratio, it is now possible to have a more reactive system (20 mm) or a more adjustable one (18 mm).\* Today the RCS brake master cylinder is available in two versions: 19 or 15.

These numbers indicate the piston diameter and define the application of the master cylinders: 19RCS for double discs systems with axial or radial four pistons calipers (NON floating), 15RCS for single disc systems (SuperMoto) or dual floating two pistons calipers (4 pistons in total).

The RCS range also includes two versions of clutch master cylinders: 19 or 16. In the first case, the ratio can be changed between 18 and 20, in the second between 18 and 16.

Il sistema RCS consiste in un registro col quale è possibile modificare l'interasse leva su 18 oppure 20 mm, in modo da raggiungere il feeling ideale tra pilota e moto: variando l'interasse, infatti, è possibile rendere l'impianto frenante più reattivo e pronto (int. 20) oppure più modulabile (int. 18).\*

La pompa radiale RCS è disponibile in due versioni: 19 oppure 15. Questi numeri identificano il diametro del pistoncino e determinano il loro utilizzo: la 19RCS deve essere impiegata su impianti bidisco 4 pistoncini ma NON flottanti, mentre la 15 RCS può essere montata su impianti monodisco con pinza a 4 pistoncini oppure bidisco ma con pinze di tipo flottante.

Nella gamma RCS sono presenti anche le frizioni, con pistoncino Ø 19 o Ø 16. Nel primo caso la variazione d'interasse è stabilita in 18 – 20 mm, mentre nel tra 16 e 18 mm.

### Technical Info • Scheda descrittiva

#### Moto GP Piston

Piston, seals and push rod are the same as those used in the official MotoGP and SBK master cylinders: very narrow tolerances for the highest precision while braking.

#### Body

Produced in forged aluminium alloy, is partially CNC machined and then finished by hard anodizing process.

#### Lever

It is made by two main components: the lever drive and the "half" folding lever, both produced in forged aluminium with black finishing.

#### Micro-Switch for Rear Brake Light

For road use of the 19RCS MIC, the body has a dedicated housing for a rear light micro-switch, included in the box.

#### Pompante interno MOTO GP

Il pistoncino, le guarnizioni ed il puntalino della 19 RCS sono i medesimi delle pompe utilizzate dalla quasi totalità dei piloti della MotoGP e della SB. Ridottissime tolleranze di lavorazione e ottima scorrevolezza.

#### Corpo Pompa

Il corpo pompa è in lega d'alluminio, ottenuto tramite forgiatura e lavorato successivamente CNC con fresature d'alleggerimento. Per la finitura superficiale è stata scelta l'ossidazione dura.

#### Leva

La leva è costituita da due componenti principali: il guida Leva Racing e la leva stessa, snodata, realizzata attraverso forgiatura.

#### Interruttore Luce Stop (freno)

E' stato predisposto un alloggiamento specifico per l'interruttore meccanico di accensione luce stop, per l'utilizzo stradale della pompa freno.



1

## Radial RCS Brake M/C

**Code 110A26310** (19 RCS)

**Code 110A26320** (15 RCS Short Lever)

**Code 110A26330** (15 RCS Long Lever)



### Technical Characteristics • Caratteristiche Tecniche

<i>Pistons / Pistoni Ø</i>	19 - 15 mm.
<i>Distance center to center / Interesse leva</i>	18 / 20 mm. (adjustable)
<i>Construction Material / Materiale</i>	CNC Forged Aluminium / Alluminio Forgiato CNC
<i>Finishing / Finissaggio</i>	Hard anodizing / Anodizzazione dura
<i>Weight / Massa</i>	350 gr.
<i>Brake Fluid / Fluido freni</i>	DOT 4

### Spare Parts • Ricambi

*Lever (complete) for 19 RCS / Leva completa per 19 RCS*  
**110A26399**

*Half lever for 19 RCS / Terminale leva per 19 RCS*  
**110A26398**

*Half lever for 15 RCS / Terminale leva per 15 RCS*  
**110A26396**

*Handlebar clamp / Cavallotto*  
**110A26388**

*Bleeding screw / Vite spurgo*  
**05338763**

*Lever pivot / Perno leva*  
**110459291**

*Oil reservoir connection / Raccordo serbatoio*  
**10312720**

*Micro-switch / Micro interruttore*  
**110467195**

*Lever adj. / Regolazione leva*  
**10510730**

*Rubber cup and sticker (flag) / Tappo in gomma e adesivo (bandierina)*  
**110A26389**

## RCS Master Cylinder Accessories

1



### RCS Accessories • Accessori RCS

*"Low drag" brake lever / Leva freno con intaglio*  
**110A26378**

*"Low drag" clutch lever / Leva frizione con intaglio*  
**110A26379**

*Right clamp with M8x1,25 mirror fitting / Cavallotto destro porta specchio M8x1,25*  
**110A26380**

*Left clamp M8x1,25 / Cavallotto sinistro M8x1,25*  
**110A26381**

*Remote adjuster / Regolatore a distanza*  
**110A26384**

*Brake reservoir kit / Kit serbatoio freno*  
**110A26385**

*Clutch reservoir kit / Kit serbatoio frizione*  
**110A26386**

*CNC Clamp (red logo) / Cavallotto CNC (logo rosso)*  
**110A26387**

*CNC Clamp (std. logo) / Cavallotto CNC (logo std.)*  
**110A26388**

*Right clamp with M10x1,25 mirror fitting / Cavallotto destro porta specchio M10x1,25*  
**110A26390**

*Left clamp M10x1,25 / Cavallotto sinistro M10x1,25*  
**110A26391**

# 1 Radial Master Cylinder



## Technical Characteristics • Caratteristiche Tecniche

<i>Pistons / Pistoni Ø</i>	16 / 19 mm.
<i>Distance center to center / Interasse leva</i>	16 / 18 / 20 mm.
<i>Construction Material / Materiale</i>	CNC Forged Aluminium / Alluminio Forgiato CNC
<i>Finishing / Finissaggio</i>	Hard anodizing / Anodizzazione dura
<i>Weight / Massa</i>	286 / 306 gr.
<i>Brake Fluid / Fluido freni</i>	DOT 4

Type	Standard Level Leva Standard	Type	Standard Level Leva Standard
19x20	10476060	16x18 for single disc (short lever)	10476082
19x18	10476070	16x16 CNC for single disc	XR01130
19x16 CNC	XR01110	16x16 CNC for single disc (short lever)	XR011B0
16x18 for single disc	10476080		

Spare part levers Leve a ricambio	Standard Level Leva Standard	Folding Lever Leva Pieghevole
<i>Bent lever with axis 20 / Leva per interasse 20</i>	10459460	110523115
<i>Bent lever with axis 18 / Leva per interasse 18</i>	10459461	110523116
<i>Bent lever with axis 16 / Leva per interasse 16</i>	X104881	
<i>Short lever with axis 20 / Leva corta per interasse 20</i>	10726431	
<i>Short lever with axis 18 / Leva corta per interasse 18</i>	10726432	
<i>Short lever with axis 16 / Leva corta per interasse 16</i>	10726433	
<i>Half lever (std) XR MIC / Mezza leva (std) pompe XR</i>		X98A7E1
<i>Half lever (short) XR MIC / Mezza leva (corta) pompe XR</i>		X98A7E2
<i>Half lever (straight) XR MIC / Mezza leva (dritta) pompe XR</i>		X98A7E3
<i>Lever guide for XR MIC / Guida leva per pompe XR</i>		110726437

Spare parts • Ricambi	Code		
<i>Pushrod kit (forged MIC) / Kit Puntalino (pompe forgiate)</i>	10426660	<i>Lever pin clip / Clip perno</i>	A6500960
<i>Clamp (forged MIC) / Cavallotto forgiato</i>	10281581	<i>Stop pin / Spina elastica</i>	A51101046
<i>Clamp (CNC MIC) / Cavallotto CNC</i>	10281580	<i>Lever adjustmen knob / Pomolo regolazione leva</i>	10510710
<i>Lever pivot / Perno leva</i>	10459240	<i>Reservoir connection / Raccordo serbatoio</i>	10312710
<i>Lever adjustmen barrel / Barilotto regolazione leva</i>	10511010		

**RCS Clutch  
Master Cylinder**  
**Code 110A26350** (16 RCS)  
**Code 110A26370** (19 RCS)



1

**Technical Characteristics • Caratteristiche Tecniche**

<i>Pistons / Pistoni Ø</i>	19 - 16 mm.
<i>Distance center to center (A) / Interesse leva (A)</i>	18 / 20 mm. - 16 / 18 mm.
<i>Construction Material / Materiale</i>	<i>CNC Forged Aluminium / Alluminio Forgiato CNC</i>
<i>Finishing / Finissaggio</i>	<i>Hard anodizing / Anodizzazione dura</i>
<i>Weight / Massa</i>	350 gr.
<i>Brake Fluid / Fluido freni</i>	DOT 4

**Spare Parts • Ricambi**

*Lever (complete) / Leva completa*  
**110A26395**

*Half lever / Terminale leva*  
**110A26394**

*Handlebar clamp / Cavallotto*  
**110A26388**

*Bleeding screw / Vite spurgo*  
**05338763**

*Lever pivot / Perno leva*  
**110459291**

*Oil reservoir connection / Raccordo serbatoio*  
**10312720**

## Clutch Master Cylinder (CNC)



### Technical Characteristics • Caratteristiche Tecniche

<i>Pistons / Pistoni Ø</i>	19 - 16 mm.
<i>Distance center to center / Interesse leva</i>	16 - 18 - 20 mm.
<i>Construction Material / Materiale</i>	CNC Alu. - All.CNC
<i>Finishing / Finissaggio</i>	Hard anodizing / Anodizzazione dura
<i>Weight / Massa</i>	286/306 gr.
<i>Brake Fluid / Fluido freni</i>	DOT 4

Type	Standard Level Leva Standard	Type	Standard Level Leva Standard
16x18	10580010	16x16	X943200
19x20	10580050	16x16	XR01150
19x18	10580060	16x18	XR01151

Spare Part Levers Leve a Ricambio	Standard Level Leva Standard	Folding Lever Leva Pieghevole
<i>Bent lever with axis 20/Leva per interasse 20</i>	10459460	110523115
<i>Bent lever with axis 18/Leva per interasse 18</i>	10459461	110523116
<i>Bent lever with axis 16/Leva per interasse 16</i>	X104881	
<i>Short lever with axis 20/Leva corta per interasse 20</i>	10726431	
<i>Short lever with axis 18/Leva corta per interasse 18</i>	10726432	
<i>Short lever with axis 16/Leva corta per interasse 16</i>	10726433	
<i>Half lever (std) XR MIC / Mezza leva (std) pompe XR</i>		X98A7E1
<i>Half lever (short) XR MIC / Mezza leva (corta) pompe XR</i>		X98A7E2
<i>Half lever (straight) XR MIC / Mezza leva (dritta) pompe XR</i>		X98A7E3
<i>Lever guide (axis 16) for XR MIC / Guida leva (int. 16) per pompe XR</i>		110726437
<i>Lever guide (axis 18) for XR MIC / Guida leva (int. 18) per pompe XR</i>		110726436

Spare parts • Ricambi	Code		
<i>Clamp (CNC MIC) / Cavallotto</i>	10281570	<i>Lever pin clip / Clip perno</i>	A6500960
<i>Lever pivot / Perno leva</i>	10459240	<i>Stop pin / Spina elastica</i>	A51101046
<i>Lever adjustmen barrel / Barilotto regolazione leva</i>	10511010	<i>Lever adjustment knob / Pomolo regolazione leva</i>	10510710
			10510710

**YAMAHA R1/R6/FZ1/FZ6**  
**Mechanical**  
**Clutch Lever**  
**Code 110B01295**

---

1



**Application List • Lista Applicazione**

---

<b>Model/ Modello</b>	<b>Years / Anno</b>
R1	2002 - 2009
R6	1999 - 2009
FZ1	2006 - 2009
FZ6	2004 - 2009

1

## Lever Remote Adjuster



### Length • Lunghezza

### Code

575 mm	X205710
715 mm	X205711
625 mm	X205712

## RCS Remote Adjuster Code 110A26384



### Technical Info • Scheda Descrittiva

Directly coming from the World's top level races and with the patented CBW system (Click By Wire), this new remote adjuster guarantees the finest adjustment of the brake lever position, even in the worst race conditions. A special inner wire in combination with an outer PVC cable allow to transmit the movement fluidly and without torsions and the exceeding length can be easily cut to adapt the adjuster to any application. CNC nylon fork is included. Compatible ONLY with RCS radial master cylinders.

Con questo dispositivo derivato dalle competizioni (sistema brevettato CBW – Click by Wire), è possibile effettuare una regolazione micrometrica della distanza leva in tutte le condizioni di utilizzo più estreme, con la trasmissione della coppia che avviene in maniera fluida e senza torsioni della guaina coassiale in PVC di colore bianco. Questo Remote Adjuster può essere utilizzato SOLO con pompe tipo RCS.

**“Thumb” M/C** (Left side only)  
**PS 13 Code X985701**  
**PS 11 Code X985721**



**Technical Characteristics • Caratteristiche Tecniche**

<i>Pistons / Pistoni Ø</i>	11 / 13 mm.
<i>Distance center to center / Interasse leva</i>	16 mm.
<i>Construction Material / Materiale</i>	CNC Aluminium / Alluminio CNC
<i>Finishing / Finissaggio</i>	Hard anodizing / Anodizzazione nera
<i>Weight / Massa</i>	175 gr.
<i>Brake Fluid / Fluido freni</i>	DOT 4

**Rear Master**

**Cylinder** (To be used only with Thumb M/C)  
**PS 13 Code X963720**  
**PS 11 Code X963710**



**Technical Characteristics • Caratteristiche Tecniche**

<i>Pistons / Pistoni Ø</i>	11 / 13 mm.
<i>Construction Material / Materiale</i>	Casting Aluminium / Alluminio Fuso
<i>Finishing / Finissaggio</i>	Black Anodizing / Anodizzazione dura
<i>Weight / Massa</i>	86 gr.
<i>Brake Fluid / Fluido freni</i>	DOT 4

## Brembo Racing Discs

*During braking the disc has to dissipate the kinetic energy of the motorcycle which is normally turned into heat by the friction between the pads and the disc itself. Therefore, the latter is affected by a thermomechanic force (heat + force) that the disc naturally holds out without getting deformed. Every disc has its own inertia (i.e. the tendency of a body not to modify its motion status) which depends on the weight and the external diameter and affects the speed when shifting directions. A new disc project must take all these points into consideration and the best performance is achieved when the disc is lighter and more resistant.*

### T-Drive Disc

*"T-Drive" disc concentrates the most recent Brembo Racing technologies and knowhow, until now exclusive of MotoGP and SBK. A special "T" profile of the eight connections between rotor and drum is the innovation that makes "T-Drive" discs so different from traditional versions with cylindrical bushings.*

*This particular coupling allows to transfer braking torque more efficiently and guarantees higher resistance to thermo-mechanical stresses. T-Drive system assures both radial and axial movements (full floating) for better performances and a weight reduction which gives a consistent improvement in bike handling. The new rotor is lighter (reduced height) and more efficient thanks to new position of holes with differentiated diameters.*

*Also the drum concretely cooperates to the achievement of the best result: produced in aluminium alloy through CNC machining, has been projected to guarantee lightness and stiffness.*

### Supersport Disc

*BREMBO RACING SUPERSPORT 5,5-mm discs are fully interchangeable with the original discs and they are designed to fit to the OE calipers as well as with BREMBO Racing. These are floating discs made up of a brake rotor in thermally-treated martensitic stainless steel (capable to stand any thermomechanic strain) and of an CNC alloy-aluminium bell.*

*These two parts are connected to each other using 10 bushings. The combination of these discs with Brembo Z04 pads won the 2009 World SuperSport Championship title.*

Durante la frenata il disco dissipa l'energia cinetica della moto, attraverso il calore prodotto dall'attrito tra le pastiglie ed il disco stesso.

Quest'ultimo viene quindi sollecitato da un'azione termomeccanica alla quale il disco deve resistere senza deformarsi permanentemente.

Ogni disco è dotato della propria inerzia (tendenza di un corpo a non modificare il proprio stato di moto) dipendente da peso e diametro esterno, che, in pratica, influenza la rapidità nei cambi di direzione. Il progetto di un disco non può quindi prescindere da quanto sopra e sarà tanto migliore quanto più riuscirà a essere leggero e nel contempo resistente.

### Disco "T-Drive"

Nato dall'esperienza maturata in SBK e MotoGP, il disco "T-Drive" presenta un nuovo accoppiamento tra fascia e campana, costituito da otto perni a "T" ricavati sul disco e da otto sagome sulla campana, che consente l'eliminazione dei noddolini di trascinamento. Questo sistema garantisce la trasmissione della coppia frenante in modo più efficace e migliora la resistenza agli stress termomeccanici.

Il sistema "T-DRIVE" permette la flottanza sia radiale sia assiale e consente di ridurre il peso complessivo del disco, portando un consistente vantaggio nella guidabilità.

La fascia è stata ottimizzata sia riducendone l'altezza (più leggerezza) sia ridistribuendo la disposizione dei fori (di diametro differenziato).

Anche la campana contribuisce in maniera sostanziale al risultato finale: realizzata in lega leggera tramite lavorazioni CNC, è stata progettata per garantire leggerezza e rigidità.

### Disco SuperSport

I dischi SUPERSPORT spessore 5,5 mm. sono intercambiabili agli originali e adatti a lavorare sia con le pinze di serie che con le BREMBO Racing. Sono dischi completamente flottanti composti dalla fascia in acciaio martensitico termicamente trattato (in grado di resistere a qualsiasi sollecitazione termomeccanica) e dalla campana in lega d'alluminio ricavata dal pieno. L'accoppiamento tra i due componenti avviene per mezzo di 10 noddolini di trascinamento. Questi dischi, in combinazione con le pastiglie Brembo Z04, hanno vinto il Mondiale SuperSport 2009.



## T-Drive Disc

1



### Technical Characteristics • Caratteristiche Tecniche

<i>Mounting / Fissaggio</i>	<i>As original / Come originale</i>
<i>Rotor height / Altezza fascia</i>	33,2 mm.
<i>Rotor thicknes / Spessore fascia</i>	5,5 mm.
<i>Rotor material / Materiale fascia</i>	<i>Stainless steel / Acciaio inox</i>
<i>Bell material / Materiale campana</i>	<i>Aluminium alloy/ Lega alluminio</i>
<i>Connection number/ Numero connessioni</i>	8

# 1 Super Sport Disc

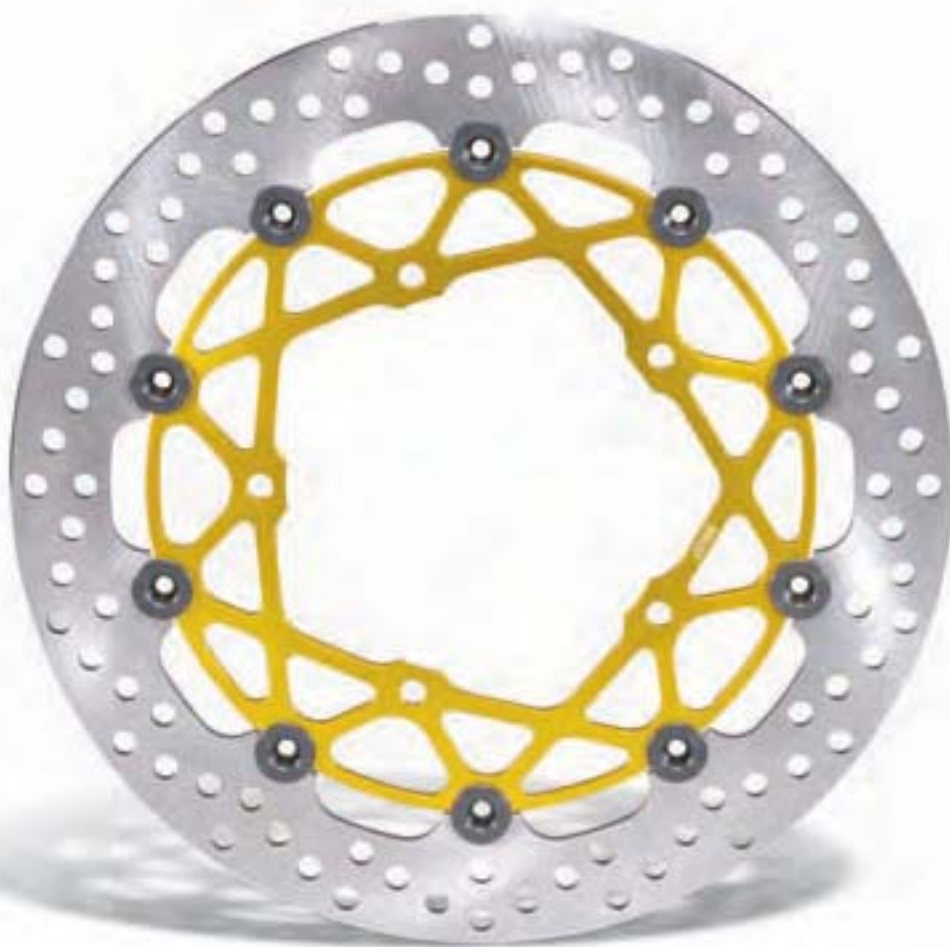

## Technical Characteristics • Caratteristiche Tecniche

<i>Mounting / Fissaggio</i>	<i>As original / Come originale</i>
<i>Rotor height / Altezza fascia</i>	34 mm.
<i>Rotor thicknes / Spessore fascia</i>	5,5 mm.
<i>Rotor material / Materiale fascia</i>	<i>Stainless steel / Acciaio inox</i>
<i>Bell material / Materiale campana</i>	<i>Aluminium alloy / Lega alluminio</i>
<i>Connection number / Numero connessioni</i>	10

## T-Drive and Supersport Discs Applications Table

Model	Year		Disc Ø	T-Drive Discs	SuperSport Discs	Note
	From	To				
<b>APRILIA</b>						
RSV1000	2000	2003	320	208.A985.10	208.9737.25	1, 9
RSV1000R	2000	2008	320	208.A985.10	208.9737.25	1, 9
RSV1000R Factory	2004	2007	320	208.A985.10	208.9737.25	1, 9
RSV4	2009	2009	320	208.A985.10	208.9737.25	1, 9
Tuono Models	2002	2006	320	208.A985.10	208.9737.25	1, 9
Tuono R	2006	2008	320	208.A985.10	208.9737.25	1, 9
Shiver 750	2007	2009	320	208.A985.10	208.9737.10	
<b>BENELLI</b>						
TNT Sport	2005	2008	320	208.A985.10	208.9737.10	
TNT Cafè	2005	2008	320	208.A985.10	208.9737.10	
TNT Titanium	2005	2008	320	208.A985.10	208.9737.10	
Tornado	2006	2008	320	208.A985.10	208.9737.10	
<b>BIMOTA</b>						
DB7	2007	2008	320	208.A985.10	208.9737.10	
<b>DUCATI</b>						
916	1994	2003	320	208.A985.10	208.9737.10	9
996, 998, excluding R models	1999	2003	320	208.A985.10	208.9737.10	9
749, 999 models	2003	2006	320	208.A985.11	208.9737.11	9
999 R/S	2003	2006	320	208.A985.11	208.9737.11	9
Monster S4R S	2003	2005	320	208.A985.10	208.9737.10	9
Monster 696	2009	2009	320	208.A985.10	208.9737.10	
Monster 1100	2009	2009	320	208.A985.36	208.9737.36	
Monster 1100 S	2009	2009	320	208.A985.11	208.9737.11	
Sport / GT	2009	2009	320	208.A985.10	208.9737.10	
848	2008	2009	320	208.A985.11	208.9737.11	
1098	2007	2008	320	208.A985.11	208.9737.11	
1198	2009	2009	320	208.A985.11	208.9737.11	
1198 S	2009	2009	320	208.A985.11	208.9737.11	
1198 R	2009	2009	320	208.A985.11	208.9737.11	
1198 R Bayliss	2009	2009	320	208.A985.11	208.9737.11	
Hypermotard	2007	2008	320	208.A985.36	208.9737.36	
Hypermotard S	2009	2009	320	208.A985.36	208.9737.36	
Streetfighter	2009	2009	320	208.A985.11	208.9737.11	
Streetfighter S	2009	2009	320	208.A985.11	208.9737.11	
<b>HONDA</b>						
VTR 1000 SP1, SP2 (RC51)	2000	2006	320	208.A985.12	208.9737.12	9
CBR 600 RR	2003	2009	310	208.A985.13	208.9737.13	9
CBR 600 RR	2005	2009	320	208.A985.12	208.9737.12	10
CBR 1000 RR	2004	2005	310	208.A985.13	208.9737.13	9
CBR 1000 RR	2004	2005	320	208.A985.12	208.9737.12	10
CBR 1000 RR	2006	2007	320	208.A985.12	208.9737.12	9
CBR 1000 RR	2008	2008	320	208.A985.31	208.9737.31	8
CBR 1000 RR (without ABS)	2009	2009	320	208.A985.31	208.9737.31	8
CB1000 RR	2008	2009	310	208.A985.13	208.9737.13	
CB1000 RR	2008	2009	320	208.A985.12	208.9737.12	

## T-Drive and Supersport Discs Applications Table

Model	Year		Disc Ø	T-Drive Discs	SuperSport Discs	Note
	From	To				
<b>KAWASAKI</b>						
ZX 6 R (600 cc)	2003	2004	300		208.9737.14	3
ZX 6 R (636 cc)	2005	2006	300		208.9737.14	9
ZX 6 RR (636 cc)	2003	2004	300		208.9737.14	3
ZX 6 RR (600 cc)	2005	2009	300		208.9737.14	9
ZX 6 RR (600 cc)	2005	2009	320	208.A985.22	208.9737.22	4
ER-6N (650cc)	2006	2009	300		208.9737.14	
Z 750 2007	2009	300		208.9737.14		
ZX 10 R	2004	2007	300		208.9737.14	9
ZX 10 R	2004	2007	320	208.A985.22	208.9737.22	4
ZX 10 R	2008	2009	310	208.A985.34	208.9737.34	8
ZX 10 R	2008	2009	320	208.A985.22	208.9737.22	4, 8
Z 1000 2007	2009	300		208.9737.14		
ZX 14 R	2006	2009	310	208.A985.34	208.9737.34	
ZX 14 R	2006	2009	320	208.A985.22	208.9737.22	
<b>KTM</b>						
Supermoto 950	2005	2008	320	208.A985.10	208.9737.10	
LC8 SM	2009	2009	320	208.A985.10	208.9737.10	
LC8 SD	2009	2009	320	208.A985.10	208.9737.10	
LC8 SD-R	2009	2009	320	208.A985.10	208.9737.10	
LC8 SM-T	2009	2009	320	208.A985.10	208.9737.10	
LC8 SM-R	2009	2009	320	208.A985.10	208.9737.10	
990 Superduke	2007	2008	320	208.A985.10	208.9737.10	7
RC8	2008	2009	320	208.A985.10	208.9737.10	9
RC8-R	2009	2009	320	208.A985.10	208.9737.10	9
<b>MV AUGUSTA</b>						
F4 750 S	2003	2007	310	208.A985.27	208.9737.27	9
F4 1000 S	2005	2007	310	208.A985.27	208.9737.27	9
F4 1000 R & Senna	2006	2007	320	208.A985.28	208.9737.28	9
F4 1078	2009	2009	320	208.A985.28	208.9737.28	9
Brutale S	2004	2005	310	208.A985.27	208.9737.27	9
Brutale 910	2006	2007	310	208.A985.27	208.9737.27	9
Brutale R	2006	2007	320	208.A985.28	208.9737.28	9
Brutale 1078	2009	2009	320	208.A985.28	208.9737.28	9
<b>SUZUKI</b>						
GSX-R 600	2001	2003	320		208.9737.15	9
GSX-R 600	2004	2005	300		208.9737.16	9
GSX-R 600	2006	2007	310	208.A985.17	208.9737.17	9
GSX-R 600	2006	2007	320	208.A985.26	208.9737.26	5
GSX-R 600	2008	2009	310	208.A985.32	208.9737.32	
GSX-R 600	2008	2009	320	208.A985.33	208.9737.33	12
GSX-R 750	2000	2003	320		208.9737.15	9
GSX-R 750	2004	2005	300		208.9737.16	9
GSX-R 750	2006	2007	310	208.A985.17	208.9737.17	9
GSX-R 750	2006	2007	320	208.A985.26	208.9737.26	5
GSX-R 750	2008	2009	310	208.A985.32	208.9737.32	

## T-Drive and Supersport Discs Applications Table

Model	Year		Disc Ø	T-Drive Discs	SuperSport Discs	Note
	From	To				
GSX-R 750	2008	2009	320	208.A985.33	208.9737.33	12
GSX-R 1000	2001	2002	320		208.9737.15	9
GSX-R 1000	2003	2004	300		208.9737.16	9
GSX-R 1000	2005	2007	310	208.A985.17	208.9737.17	9
GSX-R 1000	2005	2008	320	208.A985.26	208.9737.26	5
GSX-R 1000	2008	2008	310	208.A985.17	208.9737.17	5
GSX-R 1000	2009	2009	310	208.A985.32	208.9737.32	5
GSX-R 1000	2009	2009	320	208.A985.33	208.9737.33	6
Hayabusa	1999	2005	320		208.9737.15	9
Hayabusa	2008	2009	310	208.A985.35	208.9737.35	
B-King	2008	2009	310	208.A985.35	208.9737.35	
<b>TRIUMPH</b>						
Speed Triple	2004	2005	320	208.A985.23	208.9737.23	9
Speed Triple	2008	2009	320	208.A737.37	208.9737.37	
Street Triple	2007	2009	310	208.A737.30	208.9737.30	
675	2006	2009	310	208.A737.30	208.9737.30	
<b>YAMAHA</b>						
YZF-R6	1999	2002	300		208.9737.18	
YZF-R6	2003	2004	300		208.9737.19	
YZF-R6	2005	2009	310	208.A985.20	208.9737.20	9
YZF-R6	2005	2008	320	208.A985.21	208.9737.21	11
YZF-R6S	2006	2006	300		208.9737.19	9
FZ6	2004	2008	300		208.9737.19	
XJ6	2009	2009	300		208.9737.19	
YZF-R1	1998	2003	300		208.9737.18	9
YZF-R1	2004	2006	320	208.A985.21	208.9737.21	9
YZF-R1 SP-LE	2006	2006	320	208.A985.24	208.9737.24	9
YZF-R1	2007	2009	310	208.A985.20	208.9737.20	9
YZF-R1	2007	2009	320	208.A985.21	208.9737.21	
FZ1	2006	2009	320	208.A985.21	208.9737.21	
MT-03	2006	2009	300		208.9737.19	

All systems are front only and are direct replacements for the OEM components with exception of the upgrade bigger disc size.

**Specific Notes:**

- 1 - Aprilia applications require new disc mounting bolts, available into the disc kit
- 3 - OEM disc diameter is 280mm, 300mm discs (XXX.14) may be used by adding the spacers under the brake caliper
- 4 - OEM disc diameter is 300mm, 320mm discs (XXX.22) may be used by adding the spacers under the brake caliper
- 5 - OEM disc diameter is 310mm, 320mm discs (XXX.26) may be used by adding the spacers under the brake caliper
- 7 - The disc can not be used along with the OES caliper
- 9 - Discs with ABE approval granted by the German Ministry of Transport on TÜV certification
- 10 - OEM disc diameter is 310 mm, 320 mm discs (XXX.12 ) may be used by adding the spacer under the OEM
- 11 - OEM disc diameter is 310 mm, 320 mm discs (XXX.21 ) may be used by adding the spacer under the OEM
- 12 - OEM disc diameter is 310 mm, 320 mm discs (XXX.33) may be used by adding the spacer under the OEM

## SBK Disc



### Technical Characteristics • Caratteristiche Tecniche

<i>Mounting / Fissaggio</i>	<i>See next page / Vedi pagina successiva</i>
<i>Rotor height / Altezza fascia</i>	30 mm.
<i>Rotor thicknes / Spessore fascia</i>	6 mm.
<i>Rotor material / Materiale fascia</i>	<i>Stainless steel / Acciaio inox</i>
<i>Bell material / Materiale campana</i>	<i>Aluminium alloy/ Lega alluminio</i>
<i>Connection number/ Numero connessioni</i>	12

## SBK Discs Dimensions Table

Code	Application	Disc Ø	Inner Ø	Holes axis	Holes Ø	Holes n°	Offset mm.	Th. mm.
08670311	A	320	64,0	80,0	8,5	6	10,5	6,0
08670321	-	320	80,0	101,5	8,5	6	10,5	6,0
08670366	-	320	69,0	91,0	10,0	10	3,4	6,0
08715030	H	320	72,0	90,0	8,5	5	10,0	6,0
08715150	B	320	132,0	150,0	8,5	5	0,0	6,0
08755010	C	320	94,0	110,0	6,5	6	13,0	6,0
08755011	D	320	80,5	100,0	10,5	5	0,0	6,0
08755012	E	320	100,0	120,0	10,5	5	0,0	6,0
08755013	F	320	72,0	90,0	8,5	5	15,5	6,0
08755014	I	320	80,0	101,5	8,5	5	7,5	6,0
08715066	G	320	69,0	91,0	10,2	5	0,0	6,0
08715202	L	320	94,0	110,0	6,25	6	15,75	6,0
08670343	-	290	58,0	74,0	6,25	6	17,0	5,5
952000	-	200	==	124,0	9,0	4	0,0	3,5
<b>VENTILATED RACING DISC</b>								
XA0J434/35	-	305	72	90,0	8,5	5	11,5	8,0
08715034	-	218	69	86,0	8,2	3	12,0	8,0

### Applications list • Applicazioni

- |  |  |
|--|--|
| <p><b>A</b> &gt; Aprilia RSV / Ducati 748 - 916 - 996 - 998 / Mondial PIEGA<br/>Disc used on different version of these models, please ask<br/>Disco per varie versioni di questi modelli, chiedere per conferma</p> <p><b>B</b> &gt; Yamaha R6 '05 &gt; / R1 '04 &gt;<br/>Original disc diameter 310 / 320 mm.</p> <p><b>C</b> &gt; Honda CBR 600RR '05 &gt; / 1000RR '04 &gt;<br/>Original disc diameter 310 / 320 mm.</p> <p><b>D</b> &gt; Kawasaki ZX 10R '04 &gt; / ZX 6R '05 / '06 e ZX 6RR '05 &gt;<br/>Original disc diameter 300 mm.</p> <p><b>E</b> &gt; Suzuki GSX 600R '06- GSX 750R '06 - GSX 1000R '05 &gt;<br/>Original disc diameter 310 mm.</p> | <p><b>F</b> &gt; Ducati 749 / 999<br/>(Original replacement / Ricambio originale)</p> <p><b>G</b> &gt; Suzuki GSX 600R '97/'03 - GSX 750R '96/'03 - GSX 1000R '01/'02<br/>Original disc diameter 320 mm.</p> <p><b>G</b> &gt; Suzuki GSX 600R '04/'05 - GSX 750R '04/'05 - GSX 1000R '03/'04<br/>Original disc diameter 300 mm.</p> <p><b>H</b> &gt; DUCATI 999 RS (SBK clienti)<br/>(Original replacement / Ricambio originale)</p> <p><b>I</b> &gt; MV Agusta F4 750 - F4 1000 - Brutale 750/910<br/>(Original replacement / Ricambio originale)</p> <p><b>L</b> &gt; Honda CBR 1000RR '08<br/>(Original replacement / Ricambio originale)</p> |
|--|--|

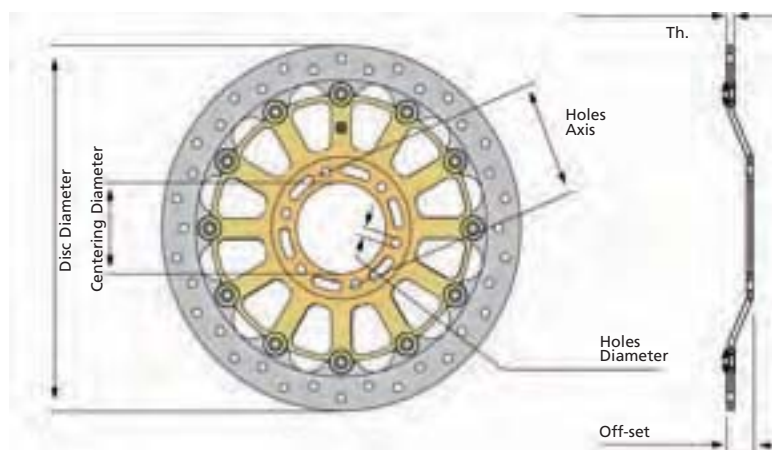

## Spacer Kits for Original Disc Diameter Kit Distanziali per Diametri Dischi Originali

Model	Year	Disc Ø OEM	Disc P/N	Spacers Kit Code for Caliper 220A01610 and 220A80210	Spacers kit Code for Caliper 220A39710 and 220B01010
<b>HONDA</b>					
CBR 600 RR	'05 - '10	310	208973713	105998709	N/A
CBR 1000 RR	'04 - '05	310	208973713	105998709	N/A
CBR 1000 RR	'06 - '07	320	208973712	105998709	105998709 *
CBR 1000 RR	'08 - '10	320	208973731	105998709	105998709 *
<b>KAWASAKI</b>					
ZX 6 R	'05 - '10	300	208973714	220A02411	105998709
ZX 10 R	'04 - '07	300	208973714	220A02411	105998709
ZX 10 R	'08 - '10	310	208973734	220A06127	220A06117
<b>SUZUKI</b>					
GSX R 600/750	'04 - '05	300	208973716	220A02411	105998709
GSX R 600/750	'06 - '07	310	208973717	220A06127	220A06117
GSX R 600/750	'08 - '10	310	208973732	220A06127	220A06117
GSX R 1000	'03 - '04	300	208973716	220A02411	105998709
GSX R 1000	'05 - '07	310	208973717	220A06127	220A06117
GSX R 1000	'08 - '10	310	208973717	220A02431	220A02421
Hayabusa	'08 - '10	310	208973735	220A02431	220A02421
<b>YAMAHA</b>					
YZF R6	'05 - '10	310	208973720	220A06125	220A06115
YZF R1	'04 - '06	320	208973721	220A06125	220A06115

\* (by removing OE Honda spacer)

## Spacer Kits for Upgrade Disc Kit Distanziali per Dischi Maggiorati

Model	Year	Disc Ø Upgrade	Disc P/N	Spacers Kit Code for Caliper 220A01610 and 220A80210	Spacers kit Code for Caliper 220A39710 and 220B01010
<b>HONDA</b>					
CBR 600 RR	'05 - '10	320	208973712	220A02411	105998709
CBR 1000 RR	'04 - '05	320	208973712	220A02411	105998709
<b>KAWASAKI</b>					
ZX 6 R	'05 - '10	320	208973722	220A02431	220A02421
ZX 10 R	'04 - '07	320	208973722	220A02431	220A02421
ZX 10 R	'08 - '10	320	208973722	220A06137	220A06177
<b>SUZUKI</b>					
GSX R 600/750	'06 - '07	320	208973726	220A06137	220A06177
GSX R 600/750	'08 - '10	320	208973733	220A06137	220A06177
GSX R 1000	'05 - '07	320	208973726	220A06137	220A06177
GSX R 1000	'08 - '10	320	208973726	220A06137	220A06177
<b>YAMAHA</b>					
YZF R6	'05 - '10	320	208973721	220A06135	220A06175

Motard

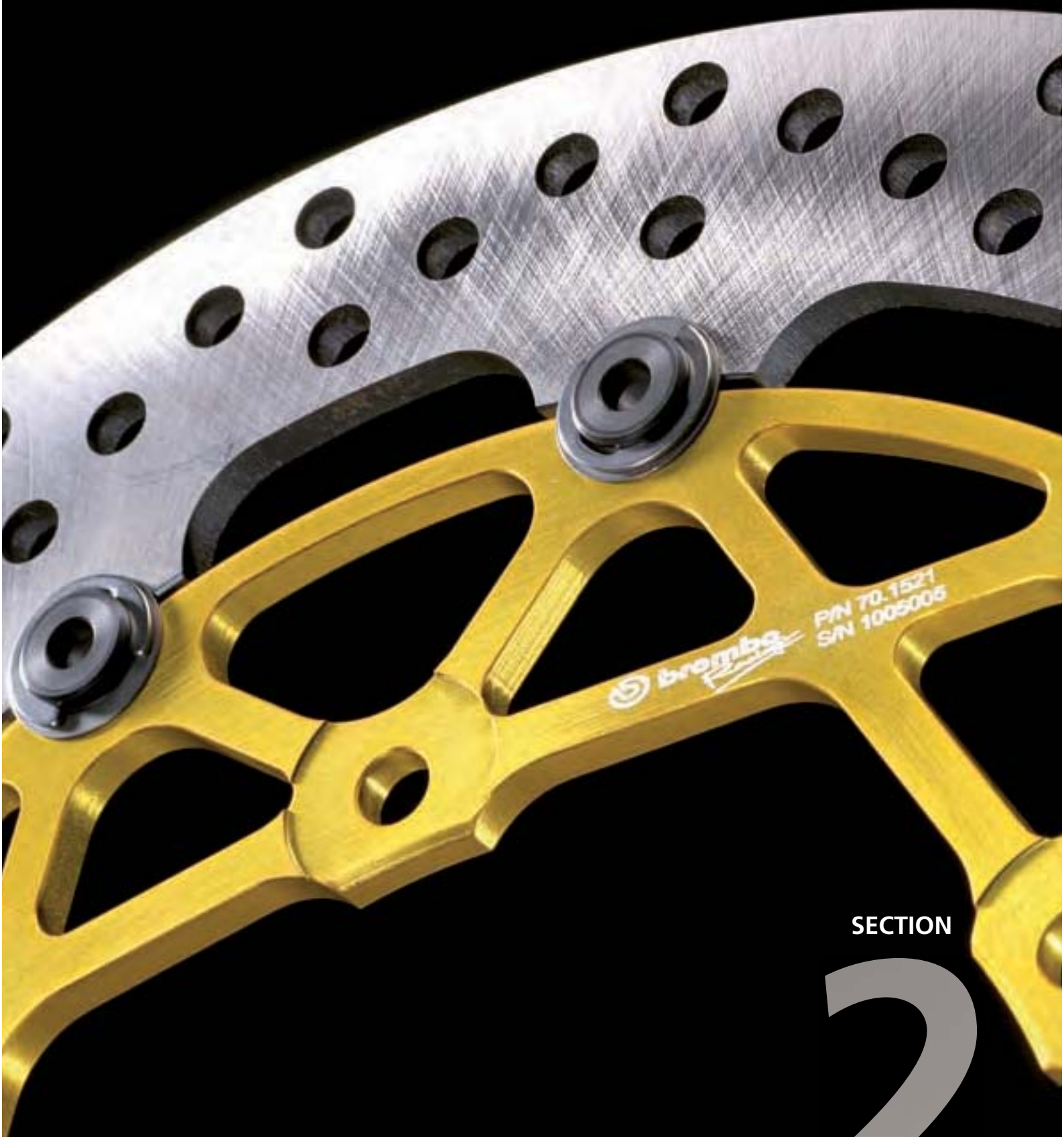

brembo  
P/N 70.1521  
S/N 1005005

SECTION

2

## Motard Radial Master Cylinder



### Technical Characteristics • Caratteristiche Tecniche

15 RCS for single disc only and short lever	110A26320
16x18 for single disc only	10476080
16x18 for single disc only and short lever	10476082
16x16 CNC for single disc only	XR01130
16x16 CNC for single disc only and short lever	XR011B0

### Spare Parts • Ricambi

Std lever with axis 18 / Leva std per interasse 18 <b>10459461</b>	Forged Clamp / Cavallotto forgiato <b>10281581</b>
Half lever for 15 RCS / Mezza leva per 15 RCS <b>11026396</b>	CNC Clamp / Cavallotto CNC <b>10281580</b>
Half lever long (XR MIC) / Mezza leva lunga (pompe XR) <b>X98A7E1</b>	Lever pivot / Perno leva <b>10459240</b>
Half lever short (XR MIC) / Mezza leva corta (pompe XR) <b>X98A7E2</b>	Lever adj. barrel / Cilindro regolazione leva <b>10511010</b>
Lever guide for XR MIC / Guida leva per pompe XR <b>110726437</b>	Lever pin clip / Clip ritegno perno leva <b>A6500960</b>
Short lever with axis 18 / Leva corta per interasse 18 <b>10726432</b>	Stop pin / Spina elastica <b>A51101046</b>
Short lever with axis 16 / Leva corta per interasse 16 <b>10726433</b>	Lever adj. knob / Regolazione leva <b>10510710</b>
Pushrod kit (for forged MICylinder only) / Kit Puntalino (solo per pompe forgiate) <b>110426660</b>	

## Radial Caliper P4 32/36

**Code XA3B860/61**

(Steel hardware/alu pistons)

**Code XA3B830/31**

(Titanium hardware and pistons)

### Spare Parts • Ricambi

*Spindle / Perno*

20696450 (for 60/61) 20696410 (for 30/31)

*Pin / Copiglia*

05454232 (for 60/61) 05454221 (for 30/31)

*Bleeding screw / Vite spurgo*

05281213



2

### Technical Characteristics • Caratteristiche Tecniche

<i>Pistons / Pistoni Ø</i>	32 / 36 mm.
<i>Construction Material / Materiale</i>	CNC Aluminium / Alluminio CNC
<i>Finishing / Finissaggio</i>	Hard anodizing / Anodizzazione dura
<i>Weight (without pads) / Massa (senza pastiglie)</i>	659 gr.
<i>Brake Fluid / Fluido freni</i>	DOT 4
<i>Hardware / Viteria</i>	Steel / Acciaio - Titanium / Titanio
<i>Pistons / Pistoni</i>	Aluminium / Alluminio - Titanium / Titanio
<i>Center to center / Interasse</i>	108 mm.
<i>Offset / Offset</i>	22,5 mm.

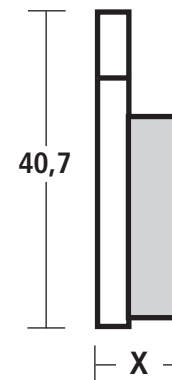
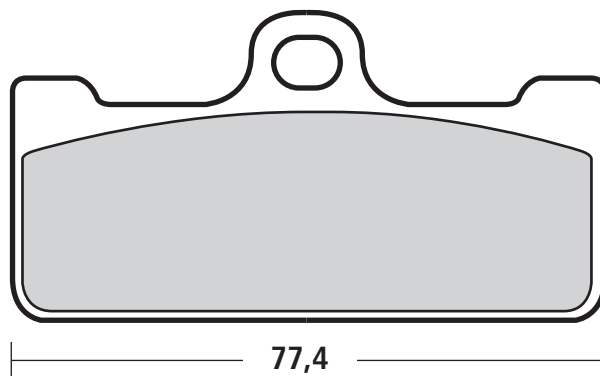

### Pads • Pastiglie

Code	Performance	Life
107684830	•	•
Z01 Th. = 8,4		
M028Z04	+	•
Z04 Th. = 8		

## 108 mm Motard Radial Caliper P4 30/34 Code XA69510



### Spare Parts • Ricambi

Spindle / Perno  
20394230

Pin / Copiglia  
05454217

Bleeding screw / Vite spurgo  
05281228

### Technical Characteristics • Caratteristiche Tecniche

Pistons / Pistoni Ø	30 / 34 mm.
Construction Material / Materiale	CNC Aluminium / Alluminio CNC
Finishing / Finissaggio	Hard anodizing / Anodizzazione dura
Weight / Massa	610 gr.
Brake Fluid / Fluido freni	DOT 4
Hardware / Viteria	Steel / Acciaio
Pistons / Pistoni	Aluminium / Alluminio
Center to center / Interasse	108 mm.
Offset / Offset	22,5 mm.

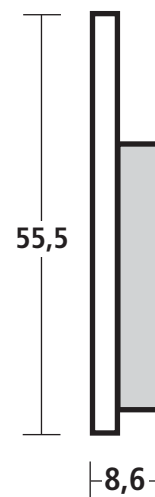
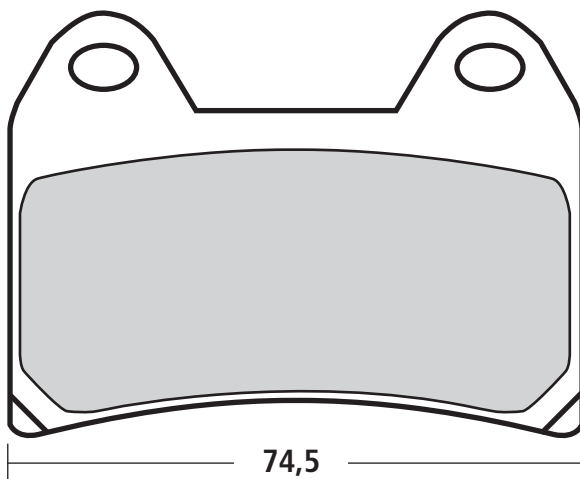

### Pads • Pastiglie

Code	Performance	Life
107670821	•	•
Genuine		
07BB1950	•	•
Genuine		

### Pads • Pastiglie

Code	Performance	Life
07BB19RC	+	•
RC Compound		
107670823	++	•
Z04 Compound		

# 100 mm Motard Radial Caliper P4 30/34 Code XA78910

## Spare Parts • Ricambi

Spindle / Perno

20394230

Spring / Molletta

05454217

Bleeding screw / Vite spurgo

05281228



2

## Technical Characteristics • Caratteristiche Tecniche

Pistons / Pistoni Ø	30 / 34 mm.
Construction Material / Materiale	CNC Aluminium / Alluminio CNC
Finishing / Finissaggio	Hard anodizing / Anodizzazione dura
Weight / Massa	710 gr.
Brake Fluid / Fluido freni	DOT 4
Hardware / Viteria	Steel / Acciaio
Pistons / Pistoni	Aluminium / Alluminio
Center to center / Interasse	100 mm.
Offset / Offset	30 mm .

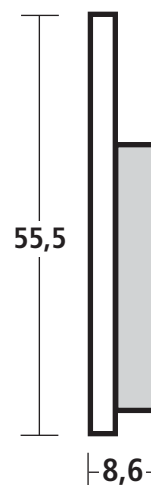
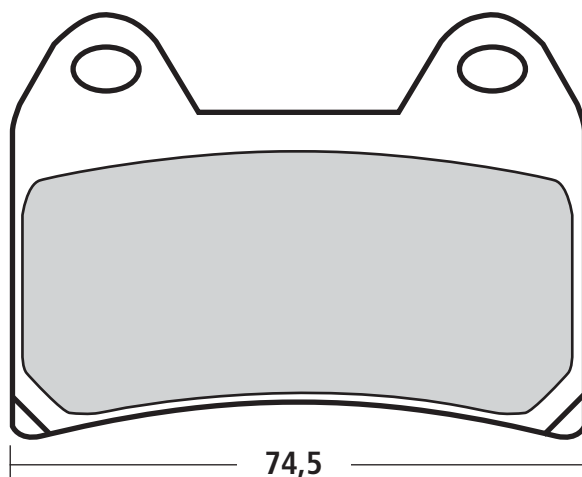

## Pads • Pastiglie

Code	Performance	Life
107670821	•	•
Genuine		
07BB1950	•	•
Genuine		

## Pads • Pastiglie

Code	Performance	Life
07BB19RC	+	•
RC Compound		
107670823	++	•
Z04 Compound		

## Motard Axial Caliper P4 34 Code XA32950

### Spare Parts • Ricambi

Spindle / Perno

22484956

Bleeding screw / Vite spurgo

05281552



### Technical Characteristics • Caratteristiche Tecniche

Pistons / Pistoni Ø	34 mm.
Construction Material / Materiale	Casting Aluminium / Alluminio fuso
Finishing / Finissaggio	Black anodizing / Anodizzazione nera
Weight / Massa	748 gr.
Brake Fluid / Fluido freni	DOT 4
Hardware / Viteria	Steel / Acciaio
Pistons / Pistoni	Aluminium / Alluminio
Center to center / Interasse	65 mm.
Offset / Offset	32 mm.

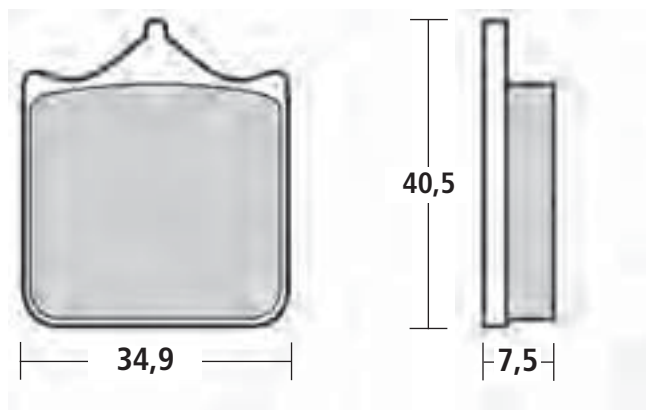

### Pads • Pastiglie

Code	Performance	Life
07BB0510 Z01	•	•
07BB05RC RC	+	•
M478Z04 Z04	++	•

## Motard Disc



### Technical Characteristics • Caratteristiche Tecniche

<i>Mounting - off-set / Fissaggio - off-set</i>	<i>As original / Come originale</i>
<i>Rotor height / Altezza fascia</i>	34 mm.
<i>Rotor thickness / Spessore fascia</i>	5,5 mm.
<i>Rotor material / Materiale fascia</i>	<i>Stainless steel / Acciaio inox</i>
<i>Bell material / Materiale campana</i>	<i>Aluminium alloy / Lega alluminio</i>
<i>Bushing number / n° nottolini</i>	10

## Motard disc application list

Model	Year		Disc ø	Code
	From	To		
<b>APRILIA</b>				
SXV 450	'05	'09	320	108.A642.15
SXV 550	'05	'09	320	108.A642.15
<b>HONDA</b>				
CR 125	'02	'09	320	108.A642.11
CR - R 125	'02	'09	320	108.A642.11
CR 250	'02	'09	320	108.A642.11
CRF 250	'02	'09	320	108.A642.11
CRF 250X	'02	'09	320	108.A642.11
CRF 450	'02	'09	320	108.A642.11
CRF 450X	'02	'09	320	108.A642.11
<b>KTM</b>				
EXC 125	'98	'08	320	108.A642.12
SX SXS 125	'00	'08	320	108.A642.12
SX 144	'07	'08	320	108.A642.12
EXC 200	'98	'09	320	108.A642.12
SX 200	'03	'08	320	108.A642.12
EXC - EXC F - EXC G 250	'04	'09	320	108.A642.12
SX - SX F - SXS 250	'03	'08	320	108.A642.12
EXC - SX 300	'00	'03	320	108.A642.12
EXC G 450	'03	'09	320	108.A642.12
EXC R 450	'08	'09	320	108.A642.12
SMR 450	'04	'08	320	108.A642.12
SXS - SXS F 450	'03	'08	320	108.A642.12
SMS 525	'04	'05	320	108.A642.12
EXC-G 525	'03	'08	320	108.A642.12
SMR 525	'04	'05	320	108.A642.12
XC - XCG - XCW 525	'06	'08	320	108.A642.12
SXS 540	'01	'06	320	108.A642.12
LC4 SC SUPERM. 620	'00	'04	320	108.A642.12
SMC 625	'05	'08	320	108.A642.12
SXC 625	'03	'08	320	108.A642.12
LC4 SUPERM. 625	'02	'04	320	108.A642.12
LC4 SUPERM. 640	'99	'07	320	108.A642.12
SMC 660	'03	'07	320	108.A642.12
SUPERMOTO 690 (not version "R")	'07	'09	320	108.A642.12

Model	Year		Disc ø	Code
	From	To		
<b>HUSABERG</b>				
FE 400	'00	'03	320	108.A642.12
FE E 400	'01	'03	320	108.A642.12
FS C - FS E 400	'01	'03	320	108.A642.12
FE E 501	'99	'04	320	108.A642.12
FC 550	'01	'05	320	108.A642.12
FE E 550	'04	'05	320	108.A642.12
FE E	'99	'03	320	108.A642.12
<b>SUPERM. 600</b>				
FE E 650	'01	'05	320	108.A642.12
FS E -C 650	'01	'08	320	108.A642.12
FX E 650	'01	'05	320	108.A642.12
<b>HUSQVARNA</b>				
SMR 450	'03	'04	320	108.A642.16
SMR RR 450	'06	'08	320	108.A642.16
SMR 570	'00	'04	320	108.A642.16
SMR 510	'05	'08	320	108.A642.16
TC - TE 570	'00	'04	320	108.A642.16
SM 610	'05	'06	320	108.A642.16
SMS 610	'00	'04	320	108.A642.16
SMS ie 610	'07	'08	320	108.A642.16
TE - TC 610	'00	'04	320	108.A642.16
SMR 630	'03	'04	320	108.A642.16
<b>KAWASAKI</b>				
KX 125	'06	'08	320	108.A642.17
KX 250	'06	'08	320	108.A642.17
KL2 450	'07	'09	320	108.A642.17
KXF 250	'06	'09	320	108.A642.17
KLX R 450	'07	'09	320	108.A642.17
KXF 450	'06	'09	320	108.A642.17
<b>SUZUKI</b>				
RMZ 250	'04	'09	320	108.A642.14
RMZ 450	'04	'09	320	108.A642.14
<b>YAMAHA</b>				
YZF 400	'98	'00	320	108.A642.18
YZF 426	'00	'02	320	108.A642.18
YZF 450	'03	'07	320	108.A642.18

Off Road



SECTION

3

## Motocross Radial Caliper P4 26/28 Code XA1K480

### Spare Parts • Ricambi

Spring / Molletta  
XA1K445

---

Pin / Copiglia  
XA1K486

---



### Technical Characteristics • Caratteristiche Tecniche

Pistons / Pistoni Ø	26 / 28 mm.
Construction Material / Materiale	CNC Aluminium / Alluminio CNC
Finishing / Finissaggio	Hard anodizing / Anodizzazione dura
Weight / Massa	485 gr.
Brake Fluid / Fluido freni	DOT 4
Hardware / Viteria	Titanium / Titanio
Pistons / Pistoni	Titanium / Titanio
Center to center / Interasse	40 mm.
Offset / Offset	20,8 mm.

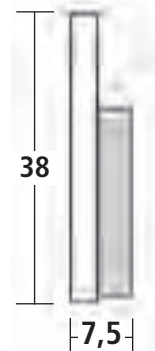
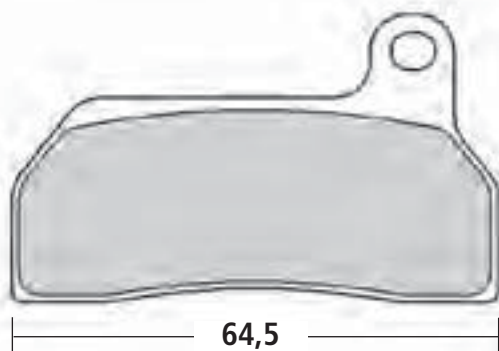

### Pads • Pastiglie

Code	Performance	Life
M057Z04	•	•
Z04		

## Off Road Caliper P2 28 Code XQ21361

### Spare Parts • Ricambi

Rubber Bellows Kit / Kit cuffia  
22474614

Spring and Blade Kit / Kit Molla-Lamierino  
20468320

Bleeding screw / Vite spurgo  
05338753



3

### Technical Characteristics • Caratteristiche Tecniche

Pistons / Pistoni Ø	28 mm.
Construction Material / Materiale	CNC Aluminium / Alluminio CNC
Finishing / Finissaggio	Hard anodizing / Anodizzazione dura
Weight / Massa	595 gr.
Brake Fluid / Fluido freni	DOT 4
Hardware / Viteria	Titanium / Titanio
Pistons / Pistoni	Titanium / Titanio

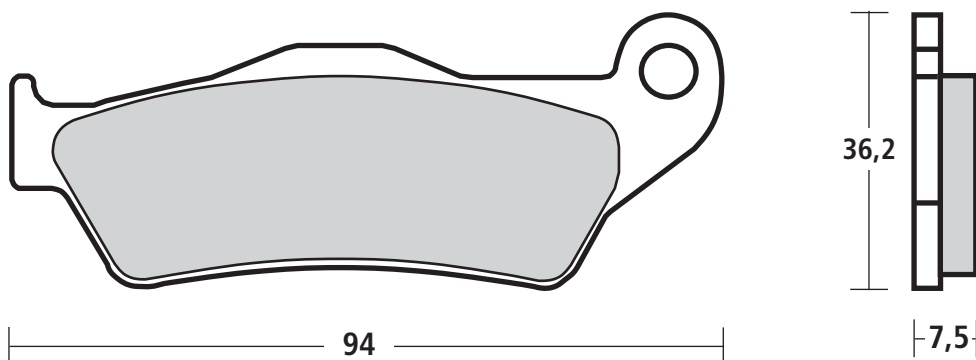

### Pads • Pastiglie

Code	Performance	Life
107861750	•	•
M9467Z04	++	+
Z04		

## Off Road Caliper P2 24 Code 122A99021



### Spare Parts • Ricambi

Rubber Bellows Kit / Kit cuffia  
122474614

Spring and Blade Kit / Kit Molla-Lamierino  
120468329

### Technical Characteristics • Caratteristiche Tecniche

Pistons / Pistoni Ø	24 mm.
Construction Material / Materiale	CNC Aluminium / Alluminio CNC
Finishing / Finissaggio	Hard anodizing / Anodizzazione dura
Weight / Massa	716 gr.
Brake Fluid / Fluidi freni	DOT 4
Hardware / Viteria	Steel / Acciaio
Pistons / Pistoni	Aluminum / Alluminio

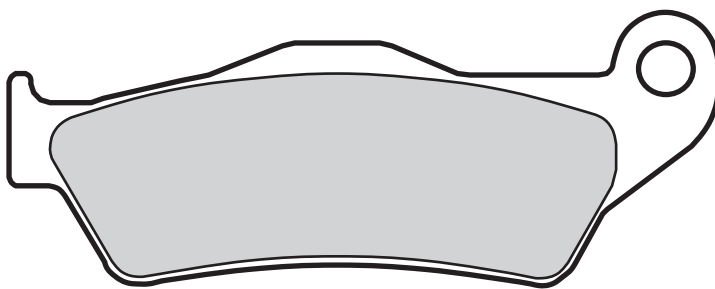

94

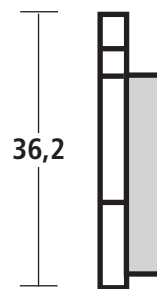

36,2

7,5

### Pads • Pastiglie

Code	Performance	Life
07849312/27 SINTER	•	•
M9467Z04 Z04	++	+

**Off Road  
Rear Caliper  
PF 26  
Code XQ21390**

**Spare Parts • Ricambi**

Rubber Bellows Kit / Kit cuffia  
22474614

Spring and Blade Kit / Kit Molla-Lamierino  
20468327

Pin / Copiglia  
22508932



3

**Technical Characteristics • Caratteristiche Tecniche**

Pistons / Pistoni Ø	26 mm.
Construction Material / Materiale	CNC Aluminium / Alluminio CNC
Finishing / Finissaggio	Hard anodizing / Anodizzazione dura
Weight / Massa	595 gr.
Brake Fluid / Fluido freni	DOT 4
Hardware / Viteria	Steel / Acciaio
Pistons / Pistoni	Aluminium / Alluminio

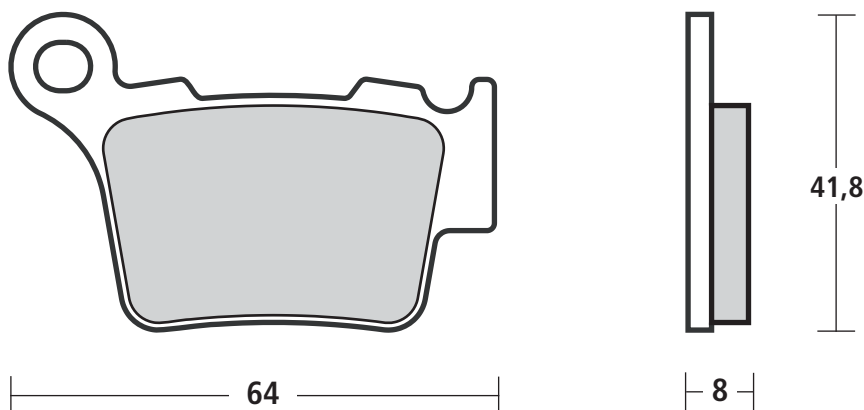

**Pads • Pastiglie**

Code	Performance	Life
07849312/27	•	•

## Motocross Master Cylinder Ø10 Code XA2B390



### Technical Characteristics • Caratteristiche Tecniche

<i>Pistons / Pistoni Ø</i>	10 mm.
<i>Distance Center to Center / Interasse leva</i>	19 mm.
<i>Construction Material / Materiale</i>	CNC Casted Aluminium / Alluminio fuso CNC
<i>Finishing / Finissaggio</i>	Black anodizing / Anodizzazione nera
<i>Weight / Massa</i>	275 gr.
<i>Brake Fluid / Fluido freni</i>	DOT 4

### Spare Parts • Ricambi

<i>Spindle / Perno</i> <b>20394230</b>	<i>Bleeding screw / Vite spurgo</i> <b>05281228</b>
<i>Spring / Molletta</i> <b>20225590</b>	<i>Dust cover / Cappuccio parapolvere</i> <b>10353051</b>

## Motocross Master Cylinder Ø9 Code 10767720



3

### Technical Characteristics • Caratteristiche Tecniche

<i>Pistons / Pistoni Ø</i>	9 mm.
<i>Distance Center to Center / Interasse leva</i>	19 mm.
<i>Construction Material / Materiale</i>	CNC Casted Aluminium / Alluminio fuso CNC
<i>Finishing / Finissaggio</i>	Black anodizing / Anodizzazione nera
<i>Weight / Massa</i>	280 gr.
<i>Brake Fluid / Fluido freni</i>	DOT 4

### Spare Parts • Ricambi

<i>Lever / leva</i> <b>110459407</b>	<i>Dust Cover / Cuffia Parapolvere</i> <b>110353051</b>
<i>Clamp / Cavallotto</i> <b>110281522</b>	<i>Anti Bubble / Membrana Serbatoio</i> <b>110477110</b>
<i>Reservoir cap / Tappo del Serbatoio</i> <b>110270477</b>	

## Enduro Master Cylinder Ø 10 Code XA2B380



### Technical Characteristics • Caratteristiche Tecniche

<i>Pistons / Pistoni Ø</i>	10 mm.
<i>Distance Center to Center / Interass leva</i>	19 mm.
<i>Construction Material / Materiale</i>	CNC Casted Aluminium / Alluminio fuso CNC
<i>Finishing / Finissaggio</i>	Silver anodizing / Anodizzazione argento
<i>Weight / Massa</i>	280 gr.
<i>Brake Fluid / Fluido freni</i>	DOT 4
<i>Supplied with microswitch for STOP light.</i>	Completa di microswitch accensione STOP.

### Spare Parts • Ricambi

<i>Lever / leva</i> <b>110459478</b>	<i>Reservoir cap / Tappo del Serbatoio</i> <b>110270477</b>
<i>Clamp / Cavallotto</i> <b>110281522</b>	

**Off Road  
Clutch Ø 10  
Code XR01610**



3

**Technical Characteristics • Caratteristiche Tecniche**

<i>Pistons / Pistoni Ø</i>	10 mm.
<i>Distance Center to Center / Interasse leva</i>	17,7 mm.
<i>Construction Material / Materiale</i>	<i>CNC Casted Aluminium / Alluminio fuso CNC</i>
<i>Finishing / Finissaggio</i>	<i>Black anodizing / Anodizzazione nera</i>
<i>Weight / Massa</i>	320 gr.
<i>Brake Fluid / Fluido freni</i>	DOT 4

# Limited Warranty

BREMBO S.p.A. ("Manufacturer") warrants to the original user, for a period of 8 days or such longer period required by law, that this Product complies with the specifications therefore and is free from defects in materials and workmanship. In the event a defect in workmanship or materials of the Product is claimed, within 8 days from its discovery or within such longer period required by law, upon its return to Manufacturer, together with a receipt containing its purchase date, the Product will be, in the Manufacturer's sole judgment, either repaired or replaced by a new or rebuilt Product. This Limited Warranty is the sole warranty made with regard to this Product.

THERE ARE NO OTHER WARRANTIES, EXPRESS OR IMPLIED, INCLUDING (WITHOUT LIMITATION) THE WARRANTIES OF MERCHANTABILITY OR FITNESS FOR A PARTICULAR PURPOSE.

In the event of a breach of this Limited Warranty Manufacturer shall have no liability for incidental, or consequential damages whatsoever and in no event shall be liable for any damages in excess of claimant's purchase price for the Product. All claims under this Limited Warranty must be made in writing promptly following the discovery of the alleged defect, and the claimed defective Product or defective part(s) returned, postage prepaid, to BREMBO S.p.A.

This Limited Warranty sets forth the sole liability of Manufacturer hereunder, and it may not be changed by any dealer, distributor or other person. This Limited Warranty shall be governed, construed and interpreted in accordance with the Italian law.

## GENERAL AND SAFETY INFORMATION

This BREMBO product has been designed to comply with all applicable safety standards. Products are not intended to be used differently from the specific use for which they have been designed and manufactured. Use for any other purpose, or any modification to, or tampering with, the Product can affect the performance of the Product and may render the Product unsafe. Such modification or improper use will void the Limited Warranty, and may subject the individual so using the Product to liability for bodily injury or property damage to others.

*La BREMBO S.p.A. ("Produttore") garantisce all'utilizzatore originario, per un periodo di 8 giorni o più a seconda di quanto stabilito dalla legge, che il Prodotto corrisponde alle specifiche indicate ed è privo di difetti nei materiali e nella lavorazione. Nel caso vengano rilevati difetti nei materiali o nella lavorazione del Prodotto e comunicati entro 8 giorni dal rilevamento o in un periodo più lungo a seconda di quanto stabilito dalla legge, il Prodotto verrà, una volta reso al Produttore con una ricevuta che ne certifichi la data di acquisto, e ad insindacabile giudizio del Produttore stesso, riparato o sostituito con un prodotto nuovo o revisionato a fondo. Le presenti Limitazioni di Garanzia costituiscono l'unica garanzia fornita in relazione al presente prodotto. NON SUSSISTONO ULTERIORI GARANZIE, ESPLICITE O IMPLICITE, COMPRESSE (SENZA LIMITAZIONE) LE GARANZIE DI COMMERCIALIZZABILITA' O IDONEITA' PER UN USO SPECIFICO.*

*Nel caso di violazione di quanto stabilito dalle presenti Limitazioni di Garanzia, il Produttore non avrà alcuna responsabilità in caso di danni accidentali o conseguenti e non potrà in alcun caso essere considerato responsabile per alcun danno che superi il prezzo d'acquisto pagato dal ricorrente per il Prodotto. Qualsiasi reclamo previsto dalle presenti Limitazioni di Garanzia dovrà essere presentato per iscritto immediatamente dopo il rilevamento del presunto difetto, inoltre il Prodotto che si presume difettoso, o le parti, dovranno essere spediti alla Brembo S.p.A. con spese a carico del mittente. Le presenti Limitazioni di Garanzia stabiliscono la responsabilità unica del Produttore e non possono essere in alcun modo modificate da fornitore, distributore o altra parte. Le presenti Limitazioni di Garanzia saranno regolate e interpretate secondo la legislazione Italiana.*

## INFORMAZIONI GENERALI E SULLA SICUREZZA

*Il presente prodotto BREMBO è stato progettato per rispettare i migliori standard di sicurezza. I Prodotti non devono essere impiegati per un uso diverso da quello per cui sono stati progettati e prodotti. L'utilizzo per scopi diversi, la modifica o la manomissione del prodotto possono alterare il funzionamento del Prodotto stesso e comprometterne la sicurezza. Eventuali modifiche o utilizzi impropri rendono nulle le Limitazioni di Garanzia e possono rendere chi utilizza il Prodotto in queste condizioni responsabile per eventuali danni fisici o materiali causati a terzi.*

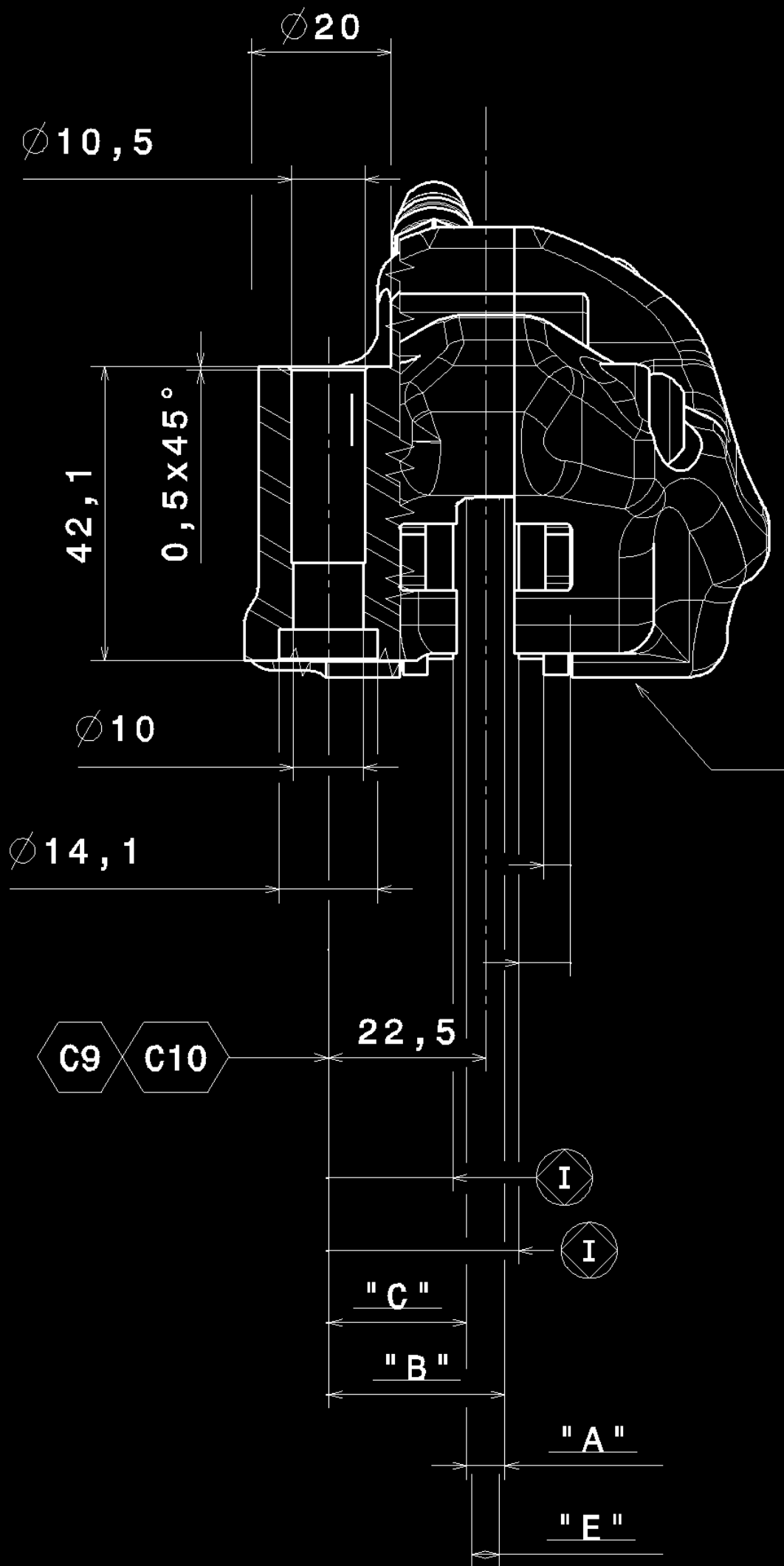

Brembo S.p.A.  
Via Brembo 25  
24035 Curno (BG) - Italy  
Tel.: +39 035 605 1111  
Fax: +39 035 605 2766  
E-mail: HighPerformance@brembo.it  
www.brembo.com



Distributed by

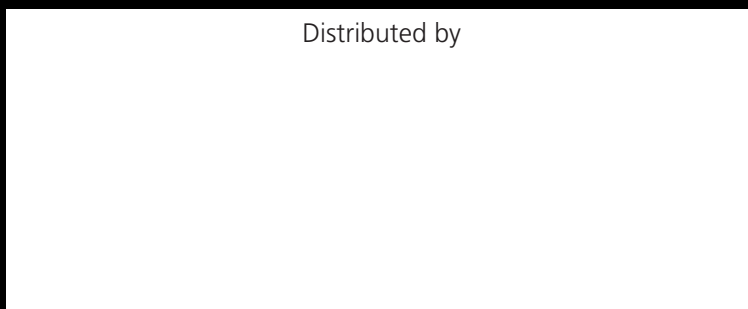

[www.brembo.com](http://www.brembo.com)

