

## PURPOSE

To show the correct procedures for the mounting and use of BREMBO braking systems for racing cars, with cast-iron brake discs.

## RESERVOIR CHOICE OF THE RESERVOIR

The capacity of the reservoir must be such that when the brake fluid is between the MIN and MAX levels the volume is at least equal to that required by the brake pistons stroke in case of maximum pad and rotor wears.

## MOUNTING OF THE RESERVOIR

- Use the pipe fittings and the washers (in copper or in rubber) foreseen by the supplier of the reservoir.
- In order to avoid any vacuum inside the reservoir, as a consequence of the brake fluid level lowering, it is always necessary to have a hole diam. 1 mm in the reservoir cap, independently from the presence of the bellows diaphragm in the reservoir.

## MASTER-CYLINDER

### CHOICE OF THE MASTER CYLINDER

- The master cylinder diameter must be chosen in function of the type of calipers which have to be fed, of the brake pedal ratio and of the max pressure we want to obtain: every variation of the master cylinder diameter involves an increase or a decrease of the master cylinder area of about 15%.
- The rubber boot, between the push rod and the hydraulic part, must always be assembled.

## BRAKE PEDAL MECHANISM (SYSTEM CONTROLLED BY 2 MASTER CYLINDERS)

- The brake pedal mechanism must be designed and manufactured in order to allow a complete stroke of both master cylinders. In case of systems where the strokes of the two master cylinders are very different from each other, it is necessary that the rod connecting the two push rods be at the appropriate angle.
- For a more linear operation of the brake pedal/master-cylinder mechanism, it is important that the distance between the pedal fulcrum and the push rods is equal or greater than 40 mm (see Fig. 1a).
- Furthermore, it is also important that in the rest position, the rod axle is placed back of 10 - 12mm compared to the fulcrum axle.
- Check that in the rest position the rod connecting the two push rods is perpendicular to both push rods.
- Check that between the joints of the rod connecting the two push rods and the pedal there is a clearance of at least 1 mm each side, in order to allow the eventual inclination of the rod compared to the push rods axle (see Fig. 1b).

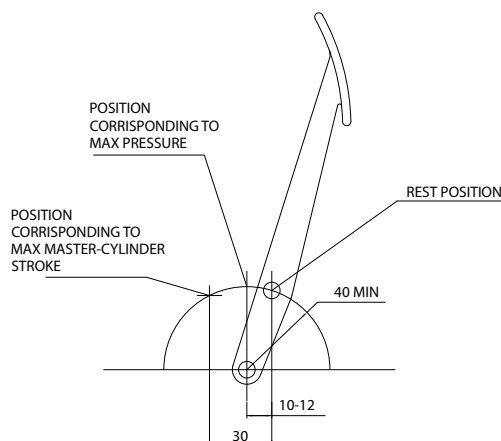

Fig. 1a

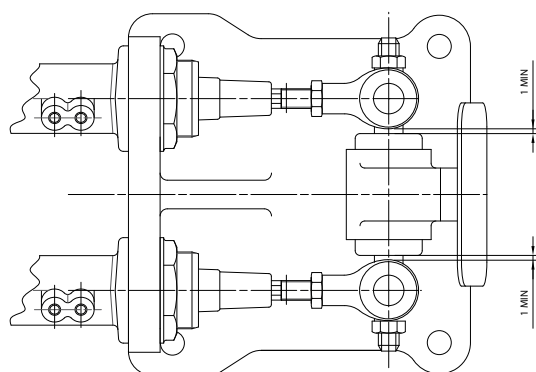

Fig. 1b

## BRAKE DISCS

### ASSEMBLY OF BELL AND DISC

- Clean the cast iron braking ring, eliminating every trace of grease or oil.
- Mount the bell on the braking ring using the BREMBO mounting bush system (the assembly of the bell on the disc must be carried out without any interference).
- Check that the "floating" is correct, that the axial clearance between braking ring and bell meets the values prescribed by Brembo.

### ASSEMBLY OF THE COMPLETE DISC ON THE WHEEL HUB

- Verify that the disc bell and wheel hub mounting faces are free from burrs and dents; otherwise these surfaces should be reconditioned.
- The disc must fit onto the wheel easily.
- Apply thermal paints on the disc external diameter (included the eventual fins and pillars) in order to monitor operating temperature.

### INSPECTIONS

- Check that the disc clearance is the one prescribed by Brembo, even after assembly on the car.
- Check before and after the use that the disc doesn't touch in any part of the caliper.

## CALIPERS

### MOUNTING

- The caliper fixing to the upright can be carried out with bolts or with gauged stud bolts and nut; this system allows a more rigid fixing and it is recommended for all the applications on calipers with the radial fixing.
- Mount the caliper onto the knuckle such that the arrow marked on the inner half-caliper corresponds to the forward direction of rotation of the brake disc (the disc must enter the caliper through the side corresponding to the smaller piston and exit through the other side corresponding to the larger piston).
- The caliper must be mounted in a symmetrical position with respect to the disc center line: the difference between the dimensions "a" and "b" must be 0,6 mm MAX (see fig. 2).

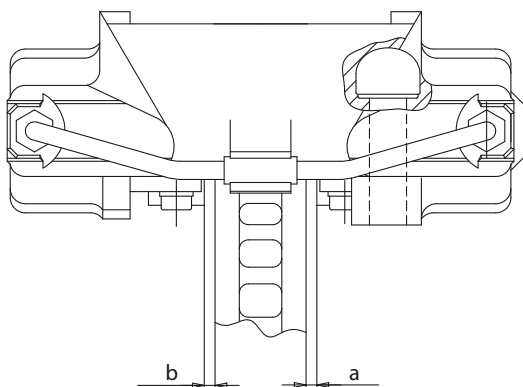

$a = b : 0,6 \text{ mm MAX}$

Fig. 2



d. The disc and pads protrusion must be 0,3 mm MAX (see Fig. 3 and Fig. 4).

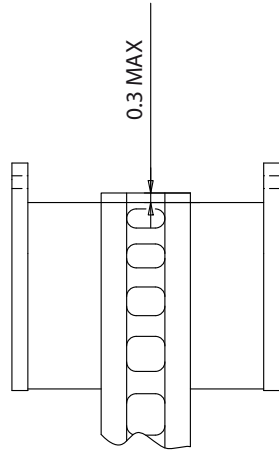

Fig. 3

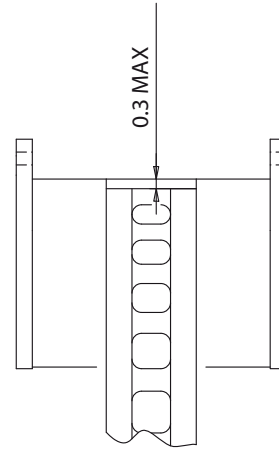

Fig. 4

- e. Check that in no working condition the pads touch the disc fixing bell or the upright.
- f. Assembly and disassembly of the pads must occur without any force; the pads radial and lateral clearance inside the caliper must be 0,2 mm MIN; with the pistons in backward position, the clearance between them and the back plate must be 0,5 mm MIN (see Fig. 5).

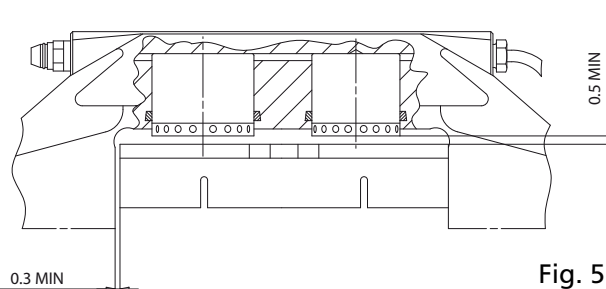
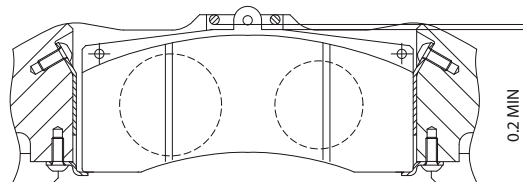

Fig. 5

- g. The clearance between disc outer circumference and Caliper Bridge must be 2 mm MIN, with a difference between the two sides of 0.4 mm MAX (see Fig. 6).

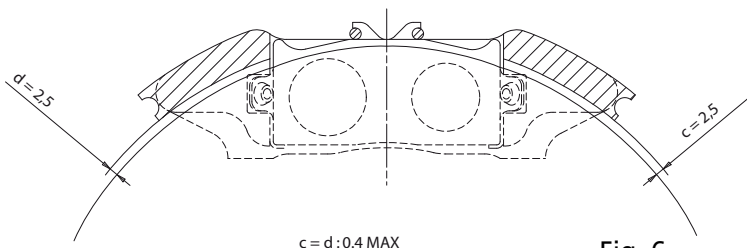

Fig. 6

- h. The M 10x1 bleed screws tightening must be carried out with a torque of 12 - 16 Nm. Apply thermal tape on the external half-caliper in order to monitor operating temperature these can be supplied by BREMBO under part number R 02.5168.10.

## MASTER-CYLINDER/CALIPER CONNECTION

### CHOICE OF TUBING

- a. Where it is possible, we recommend the use of steel rigid pipes, since they do not increase brake fluid displacement.
- b. In case, flexible brake hoses are used, it is necessary to use the Teflon type with braided steel sheath.
- c. The hoses internal diameter must be 2.5 or 3 mm; the brake fluid displacement of 1 meter of these hoses is 0.2 cm MAX (for the type having internal diameter 2.5 mm), and 0.3 cm MAX (for the type having internal diameter 3 mm) at the pressure of 70 bar; hoses with a smaller diameter restrict fluid flow, while hoses with a bigger diameter would considerably increase the brake fluid displacement of the system.

### MOUNTING

- a. Pipe fittings must be tightened to the prescribed torque.
- b. The pipe fittings seal must be sealed with annealed aluminum or copper seals; these seals can be used only once.
- c. Check that tubes are not squashed or pinched and that they are not subjected to high temperatures (in the vicinity of the engine, exhaust pipes, etc.)

## BRAKE FLUID

### CHOICE

- a. Use only high boiling point DOT 3 or DOT 4 brake fluids.
- b. Use only brake fluid from a new and sealed container.
- c. Change brake fluid before each race.

### NOTES

- a. Use of liquids other than brake fluids will damage the braking system components.
- b. Since the brake fluid is hygroscopic, we have to consider that in presence of high humidity, the boiling point can be considerably lowered; in these cases the brake fluid has to be replaced daily.



## **BRAKING SYSTEM BLEEDING**

- In the case of a braking system controlled by two parallel master cylinders operated by a rod, bleed one front and one rear caliper, in order to allow both master cylinders a complete stroke.
- Every time the pedal is back, let master cylinder refill simultaneously for at least 2 seconds before pushing the pedal.
- When the bleeding is finished, keep in pressure for at least 10 seconds, checking that there aren't any leakages.
- Refill the reservoirs.

## **WORKING INSPECTIONS**

After running a few kilometers, proceed with the following inspections:

- The wheels must rotate freely without any residual torque.
- There must be no contact between disc and caliper.
- No pulsations must be felt on the pedal, otherwise identify which disc causes the problem and check again the disc/bell and bell/hub assemblies.

## **RUNNING-IN**

For the discs and pads burnishing, it is necessary to follow the running in procedure relative to the friction material used; it is however necessary to assure that during the first kilometers, low pressure applications are carried out for short times in order to allow the bedding of all the pad surface on the disc. Only later you will

be able to proceed to the real running in which will end when every pad has reached the best working condition. The running in procedure (bedding of the disc/pads coupling surfaces) must also be carried out when already run-in or used pads are used. Only after the running in is performed, it is possible to take advantage of the braking system braking capacity.

## **BRAKING SYSTEM FINAL INSPECTIONS**

- There must not be any interference between disc and caliper.
- The max temperature reached by the calipers must be lower than 180°C (inspection to be carried out through the thermo tapes applied on the calipers - see point 6.1.h).
- Check the working temperature of the discs, verifying the changes occurred to the thermal paints applied on the external diameter of the discs (see point 5.2.c and Fig. 7):

If none of the three paints has changed and the braking system performance is not considered satisfactory, it is necessary to reduce the discs ventilation. Furthermore a rapid quick cooling could increase the risk of cracks on the discs. If all three paints change completely, it is necessary to improve the cooling. A high working temperature of the discs causes a decay of the braking power and excessively high temperatures in the brake calipers.

PAINTS COLOUR	TEMPERATURE OF TONER	NOTES
Green	430°C	Can change completely
Orange	560°C	Can change over of the braking surfaces
Red	610°C	Can change only near the braking surfaces

Fig. 7

## BRAKING SYSTEM BALANCING

The braking system has to be chosen in function of the vehicle characteristics; it is very important that the max braking power be equally distributed between the front and the rear axles; when the braking system is correctly balanced, the working temperatures of the front and rear brakes must be similar. It is possible to adjust brake balance between the front and rear axles through the adjustment rod, but only for variations up to 10% MAX: in fact the pedal force must be always applied in the vicinity of the center of the adjusting rod in order to obtain a good efficiency of the brake pedal mechanism. If the system isn't balanced even after adjusting, the causes must be searched somewhere else: master cylinders diameter, caliper type, disc diameter etc. In any case, before replacing any components, it is necessary to make sure that the combination of components works correctly. A good general rule to obtain a good efficiency is however to have as similar as possible the master cylinders loads and strokes.

## INSPECTION OF THE BRAKING SYSTEM AFTER USE

After every race, it is necessary to proceed with the following inspections and interventions:

### FITTINGS

Verify that there are no leakages from the various components, connections, or fittings. If a leak is found on one of the fittings, either increase the tightening torque, or replace the defective component.

## BRAKE DISC

Check carefully the disc braking surfaces.

The disc can't be used again if:

- on the braking surfaces there are cracks having length higher than 5 mm; in case the crack begins from the external or internal diameter, even if the length is shorter, the disc must be replaced (see Fig. 8).
- It has a wear of 1 mm compared to the new thickness (0,5 mm on both sides);
- The braking surfaces show scorings, which can damage the correct pad/disc contact.

## CALIPERS

- Check that the external half calipers connecting pipes are not bent or dented, caused i.e. by the entrance of stones between the wheel and the caliper; in case of damage, overhaul the caliper.
- Check the max temperatures reached by the caliper, checking the thermo tapes applied on the internal half caliper:

  - if a temperature of 180 °C is reached, we recommend the overhauling of the caliper or to replace the seals;
  - if a temperature of 210 °C is reached (max value of temperature the caliper can stand for short periods), it is absolutely necessary to overhaul immediately the caliper and search the causes of the overheating, since under these conditions the correct operation of the brake isn't guaranteed anymore.

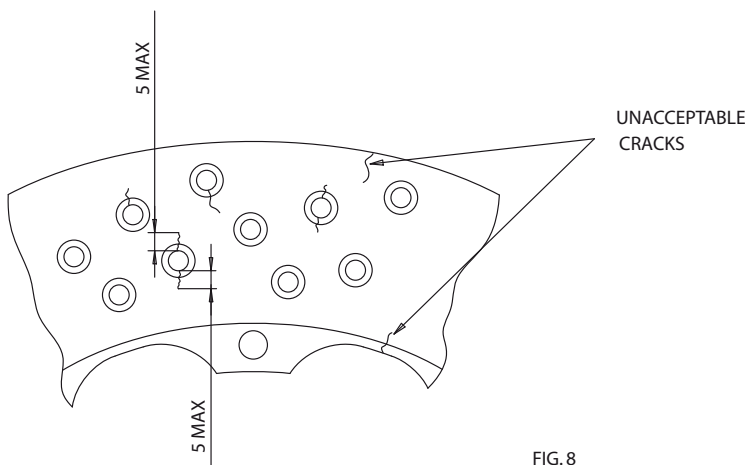

Fig. 8

FIG. 8



## PADS

### PAD WEAR INSPECTION

Pads should not have a friction material thickness lower than 2 mm MIN; if the pads are excessively worn, they must be changed.

### ABNORMAL WEAR

The pads must not show excessively anomalous or uneven wears; the following must be checked:

- a. Pad tangential taper wear difference must not exceed 1 mm MAX, bearing in mind that the direction of wears of the same caliper must be according to what shown on the Fig.9.

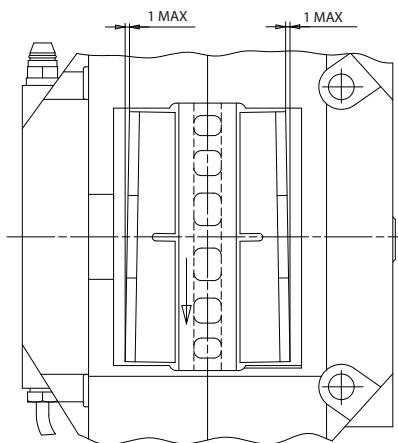

- b. Pad radial taper wear difference must not exceed 1 mm MAX, bearing in mind that the direction of wears of the same caliper must be according to what shown on the Fig.10.

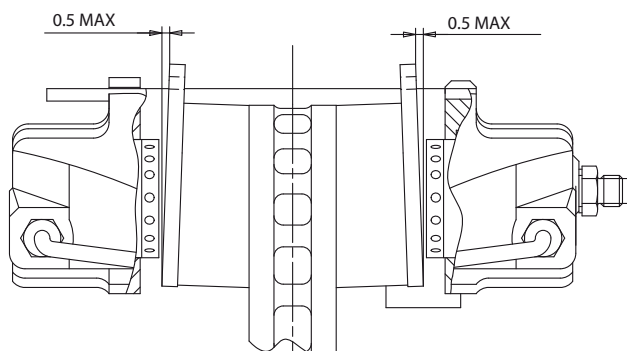

Defective or excessively worn pads must be changed.

### BACK PLATE DEFORMATION

Back plate flatness error must not exceed 0.2 mm MAX (see Fig. 11);

- in case of excessive back plate flatness error, the pads must be changed.

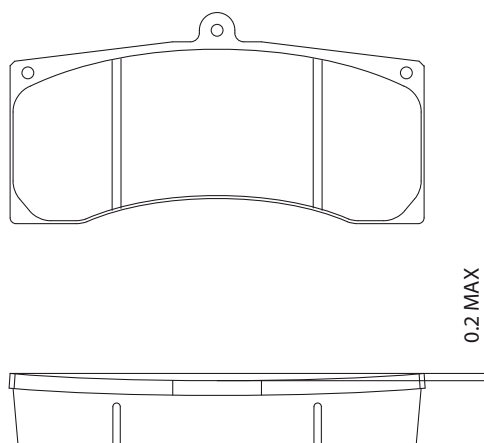

## GENERAL NOTES

### OVERHAULING AND REPLACEMENT

- Master Cylinder

These must be overhauled after 5000 km MAX of running, or when problems arise;

- Calipers

They must be overhauled after 5000 km max of running, or when problems arise, or if the temperatures go above those shown at point 14.3.b.

## VARIOUS

- a. The external cleaning of the master cylinder and calipers must be carried out with noncorrosive agents and anyway not with solvents, gasoline or similar, since these products could damage rubber components (seals and dust boots).
- b. During warehousing protect the inlet and outlet holes of the master cylinder and of the calipers with the appropriate caps.
- c. Half-caliper union bolts cannot be re-screwed, or carry out modifications to the calipers.
- d. Replacement of components with non-BREMBO parts is not permitted.
- e. BREMBO recommends the overhauling of its products through its own authorized personnel; therefore BREMBO doesn't take the responsibility for overhauling carried out by someone else.



Brembo's "racing" products are designed and manufactured to be used exclusively in competitions and, therefore, shall not be used on public roads. Thus, Brembo shall not have any liability whatsoever in connection with the use of the products in violation of such limits and/or in connection with the normal wear and tear of such products, nor shall any "Product Liability" apply in such cases. Any alteration of or tampering with the "racing" products may endanger their safety and any guarantee (concerning both contractual and tortious liability) given by Brembo in respect of the products will be terminated by any such alteration or tampering.

#### **INSTALLATION AND MAINTENANCE**

Brembo's "racing" products must be installed by highly qualified and competent professionals working in the "racing" field, who have been specifically trained to operate such kind of products. The "racing" products shall be submitted to periodical maintenance. Detailed instructions for both installation and maintenance of such products are set forth within the products wrapping (hereinafter the "instructions"). Thus, Brembo shall not have any liability whatsoever in connection with Client's failure to comply with the instructions and/or in connection with their inappropriate and/or incorrect installation on vehicles and/or with the lack of and/or incorrect maintenance of such products, nor shall any "Product Liability" apply in such cases.

#### **CONDITIONS OF USE**

The Clients acknowledge and accept that due to the particular operative and environmental conditions under which the racing products operate during competitions, such products may be subject to use under extreme conditions, which may exceed the project limits and control as set by Brembo. Thus, Brembo shall not have any liability whatsoever in connection with the use of the "racing" products under extreme conditions during the competitions, nor shall any "Product Liability" apply in such case.

#### **LIMITS TO CONTRACTUAL GUARANTEES**

Brembo guarantees that the "racing" products are manufactured with high quality materials and in accordance with the specifications provided by the Manufacturer. Should the Client, having received the "racing" products, notice either an apparent or a hidden defect, he shall communicate it in writing to Brembo within 8 (eight) days from the date of their delivery. The Client shall, at his own expense, deliver the defective products ex works BREMBO, in accordance with the instructions given by BREMBO. Only in case a defect has actually been ascertained by Brembo's quality control office, the defective parts of the "racing" products will be replaced. In any event, Brembo's liability, as well as the liability of its agents and/or distributors and/or any other brokers shall not exceed the sale price of the "racing" products. The guarantee does not apply in case the "racing" products have not been installed and maintained in accordance with the instructions. Brembo's liability does not exceed the limits set forth in this paragraph and no further guarantee, neither express nor implied, which may determine an extension of such liability, is hereby given. Except upon Brembo's express written authorization, none of its agents and/or distributors and/or other brokers are authorized to give further guarantees other than those provided for in the Sales Conditions. It should be observed that Brembo guarantees the materials produced by its suppliers within the limits of the guarantees given by such suppliers to Brembo.