

# catalogue 2008

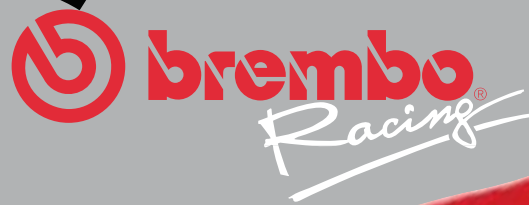

+ + + Brake Pads





Introduction	+ + + + + + + + + + + + + +	2
Brembo Racing	+ + + + + + + + + + + + + +	3
The Brembo Racing Pad	+ + + + + + + + + + + + + +	4
The Brembo Brake Fluid	+ + + + + + + + + + + + + +	5
Pad packaging	+ + + + + + + + + + + + + +	7
<b>Cars Section</b>	+ + + + + + + + + + + + + +	<b>9</b>
1 Pad list		
2 Pad drawings		
<b>Motorbikes Section</b>	+ + + + + + + + + + + + + +	<b>19</b>
1 Pad list		
2 Pad drawings		

# Introduction



## **Brembo. Number One for brakes.**

Brembo is the world's leading maker of braking systems for motor cars, motorcycles and commercial vehicles. The organization operates on 3 continents, with production sites in 9 countries and sales networks in 70 national territories around the world.

## **Research never ceases.**

Brembo has always invested in R&D, in its quest to offer a product at the leading edge, guaranteeing safety and performance. Research and Development is the focus for 6% of investments, and the efforts of 450 engineers.

## **Brembo, racing, and winning.**

For 30 years and more, Brembo has been equipping the cars and bikes of elite drivers and riders competing in motor sports at world championship level.

## **Brembo - all done in-house.**

The entire manufacturing process is an in-house operation: design, development, testing, machining, quality control, distribution, service.

## **Brembo means top quality.**

Brembo brakes are manufactured in conformity with UNI EN ISO 9004 and ISO 14001 standards. Aftermarket products are covered by the Brembo Warranty and carry ABE/TÜV certification from the German Federal Road Safety Office.

## **Top vehicle makers use Brembo.**

Brembo produces original equipment braking systems for the top vehicle makers: Aston Martin, Audi, BMW, Chrysler, Ferrari, Ford, General Motors, Honda, Jeep, Land Rover, Mercedes-Benz, Mitsubishi, Nissan, PSA, Porsche, Renault, Volkswagen, to name but a few.

## **Brembo, the parts specialist.**

Brembo is a major aftermarket supplier, producing over 15 million brake discs and drums yearly, and offering a notably broad range of pads and shoes to meet every need.



For any further explanations please refer to our website [www.brembo.com](http://www.brembo.com) racing section



# Brembo Racing

### **Brembo, number 1 for racing**

For over 30 years now, the name of Brembo Racing - synonymous with high performance braking systems - has been associated with wins by the top teams in motorsport.

### **A truly enviable honours board**

The honours won by Brembo Racing are mightily impressive: in 2006 alone, no less than 37 victories recorded by world class drivers and riders in Formula 1, Nascar, ALMS, World Rally, Moto GP, Superbike, Enduro and Cross.

### **An integrated production cycle**

All Brembo Racing products are the outcome of an integrated industrial process implemented entirely in-house, from design through manufacture to final testing, on the bench and on the track.

### **Extreme conditions, maximum performance**

Brembo is the only manufacturer in the automotive sector to offer a full range of products dedicated exclusively to Racing, on 2 and 4 wheels. Products designed to excel in the most extreme conditions: unwavering performance, braking power, absolute control, ability to withstand the highest temperatures.

### **A leading name in carbon products**

Banking continuously on research to drive innovation in technology and materials, Brembo reigns undisputed as the premier maker of high carbon discs and pads for F1 cars and MotoGP bikes.



# The Brembo Racing Pad



For 30 years and more, Brembo braking systems have been associated with the successes of top teams in motor racing.

Drawing on this experience, Brembo now launches a new range of brake pads intended exclusively for Racing.

A comprehensive range of compounds for cars (RB-170, RB-250 and RB-291) and bikes (RB-Z04), designed specifically to deliver maximum performance under the most extreme conditions.

## + + + Car Compounds

### **RB-170 compound**

Extremely high torque with aggressive controllable initial bite. Superior release and torque control characteristics. This compound is perfect for cars with high deceleration rates with or without down force. Gt cars, Rally tarmac, F3

### **RB-250 compound**

Medium friction ceramic type racing compound, fading resistant up to 650°C. The RB-250's high initial bite combined with the flat torque curve guarantees an excellent modulation characteristic and controllability. Perfect for F3 racing. Application: all single-seaters, Touring cars, GT cars, Rally cars.

### **RB-291 compounds**

Our compound for endurance racing. A slight reduction of the friction value improves the modulation (controllability). Nevertheless, the friction value is enough for cars without power-assisted brake system and ensures comfortable low effort on the brake pedal. The combination of friction value, fading stability and low wear rates on pads and discs (rotors) realised with this material is unmatched up to now. Due to its excellent release characteristics and controllability RB-291 can also be used for sprint races.. Application: All endurance racing cars.

## + + + Motorbikes Compounds

### **RB-Z04 compound**

Maximum performance for all kinds of top level racing systems. Braking power, controllability under all conditions and resistance to ultra-high temperatures are the key attributes of this pad - already the preferred component of many Superbike, Supersport and Superstock teams.



## +++ LCF 600 plus

Low compressibility factor at high temperature with more than 10% reduction in brake fluid compressibility at 180°.

High dry boiling point  
 Typical Competitor Racing Fluids 310°C  
 Brembo Racing LCF 600 plus 316°C

### Exclusively for racing use.

Brembo Racing LCF 600 plus has been specifically formulated to provide the highest performance under all racing conditions:

- an independently proven low compressibility at high temperatures
- a typical dry boiling point of 316°C (601°F)
- a typical wet boiling point of 204°C (399°F)

It even exceeds the requirements of U.S. FMVSS 116 DOT4 specification.

### Compatibility

Compatible with all Brembo Racing Brake Systems. It can be mixed with other DOT3 and DOT4 racing brake fluids but for maximum performance advantage, before filling, other types of fluid should be drained from the brake system to avoid diluting the fluid characteristic. Brembo LCF 600 plus must not be used in Brake Systems containing magnesium parts.

LCF 600 plus Racing Brake Fluid

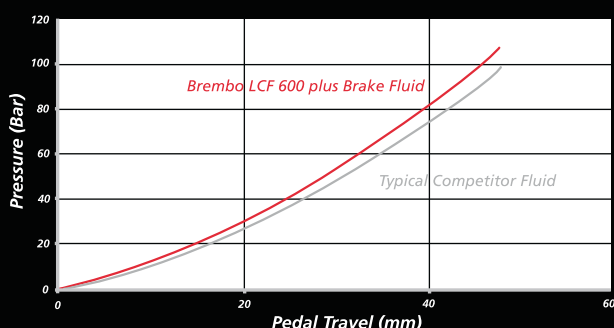

## +++ HTC 64T

High temperature brake fluid for extreme racing.

High dry boiling point  
 Typical Competitor Racing Fluids 310°C  
 Brembo Racing HTC 64T plus 335°C

### Exclusively for racing use.

Brembo Racing HTC 64T has been specifically formulated to provide the highest performance under all racing conditions.

### Compatibility

Compatible with all Brembo Racing Brake Systems. For maximum performance advantage, before filling, other types of fluid should be drained from the brake system to avoid diluting the fluid characteristic.

Brembo HTC 64T plus must not be used in Brake Systems containing magnesium parts.

HTC 64T Racing Brake Fluid

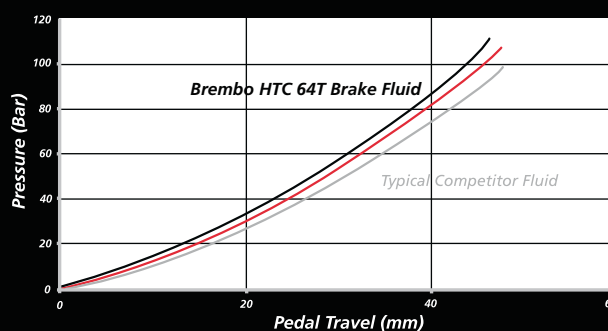



# Pad packaging



Car Pads



Motorbike Pads











# +++ Car pad list



**Brembo**  
*Racing*

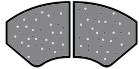
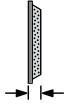
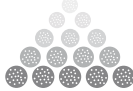



New Brembo Family	Thickness	Material	Kit p.n.	Application	Caliper
					
B08	16mm	RB-170	B08.16.170	F3 2007	Brembo
B08	16mm	RB-250	B08.16.250	F3 2007	Brembo
B09	20mm	RB-170	B09.20.170	Gr.N rear	Brembo
B09	20mm	RB-250	B09.20.250	Gr.N rear	Brembo
B10	16mm	RB-170	B10.16.170	F3 2008	Brembo
B10	16mm	RB-291	B10.16.291	F3 2008	Brembo
B10	16mm	RB-250	B10.16.250	F3 2008	Brembo
B11	14mm	RB-170	B11.14.170	OE	Brembo
B11	17mm	RB-170	B11.17.170	OE	Brembo
B12	18mm	RB-170	B12.18.170	F3000	Brembo
B13	16mm	RB-170	B13.16.170	4P Rally	Brembo
B13	22mm	RB-170	B13.22.170	4P rear Gt narrow	Brembo
B13	26,5mm	RB-170	B13.26.170	4P rear Gt	Brembo
B13	16mm	RB-250	B13.16.250	4P Rally	Brembo
B13	26,5mm	RB-291	B13.26.291	4P rear Gt	Brembo
B15	17mm	RB-170	B15.17.170	OE	Brembo
B18	17,5mm	RB-170	B18.17.170	Gr.N front Gravel	Brembo
B18	17mm	RB-250	B18.17.250	Gr.N front Gravel	Brembo
B18	20mm	RB-170	B18.20.170	Gt	Brembo
B18	26mm	RB-170	B18.26.170	Rear Gt	Brembo
B19	17,5mm	RB-170	B19.17.170	Gr.N front Tarmac	Brembo
B19	17,5mm	RB-250	B19.17.250	Gr.N front Tarmac	Brembo
B24	29mm	RB-170	B24.29.170	6P Gt	Brembo
B24	25mm	RB-170	B24.25.170	6P Gt Forged	Brembo
B24	22mm	RB-170	B24.22.170	6P Gt Narrow	Brembo
B24	29mm	RB-291	B24.29.291	6P Gt	Brembo
B25	16,1mm	RB-170	B25.16.170	Ford FPV	Brembo
B50	16mm	RB-170	B50.16.170	Various	Ap Racing
B51	25mm	RB-170	B51.25.170	6P Gt	Ap Racing
B51	28mm	RB-170	B51.28.170	6P Gt	Ap Racing
B52	17mm	RB-170	B52.17.170	Subaru Gr.N front	Ap Racing
B53	16mm	RB-170	B53.16.170	Renault Fr.2000/ Subaru Gr.N rear	Ap Racing
B53	16mm	RB-250	B53.16.250	Renault Fr.2000/ Subaru Gr.N rear	Ap Racing
B54	17mm	RB-170	B54.17.170	Various	Ap Racing
B55	26mm	RB-170	B55.26.170	6P Gt	Ap Racing
B55	30mm	RB-170	B55.30.170	6P Gt	Ap Racing
B56	25mm	RB-170	B56.25.170	6P Gt	Ap Racing
B57	18,5mm	RB-291	B57.18.291	Porsche OE	Brembo
B58	17,5mm	RB-291	B58.17.291	Porsche OE	Brembo
B59	18,5mm	RB-291	B59.18.291	Porsche OE	Brembo
B60	19mm	RB-291	B60.19.291	Porsche OE	Brembo
B61	17,5mm	RB-291	B61.17.291	Porsche OE	Brembo
B62	15mm	RB-170	B62.15.170	Mitsubishi/Subaru/ Aston Martin OE	Brembo





+ + + Car

pad drawings

**Brembo**  
*Racing*

2

**DRAWING**

**FAMILY**

**DRAWING**

**FAMILY**

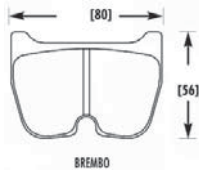

B05

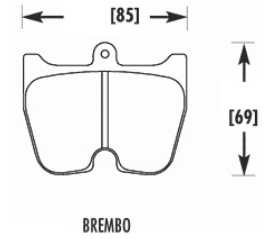

B07

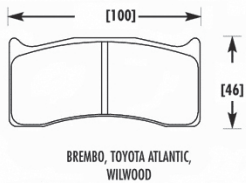

B08

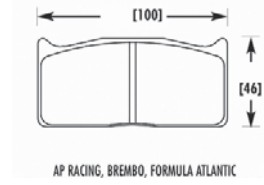

B09

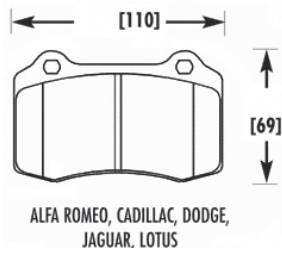

B11

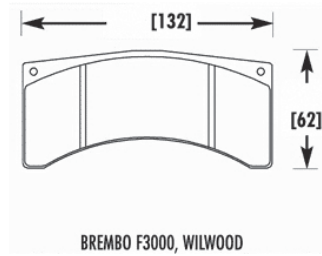

B12

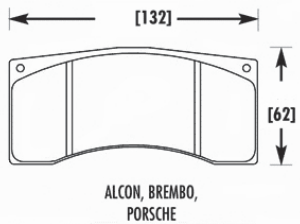

B13

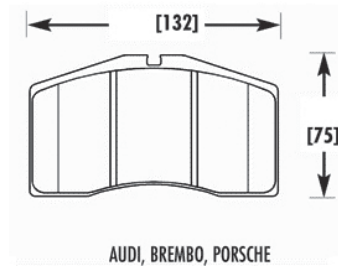

B14

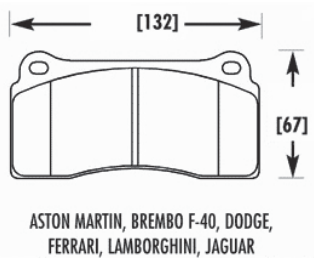

B15

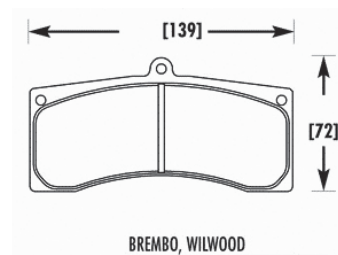

B18

scale 1:25

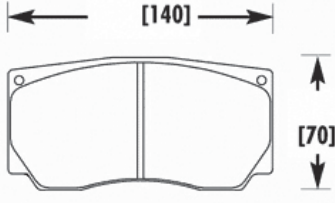
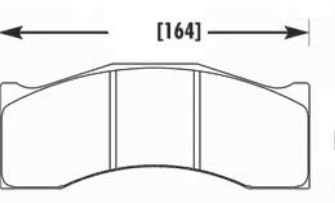
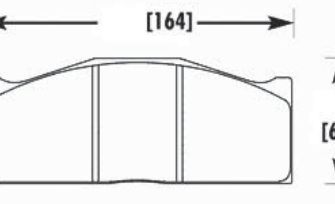
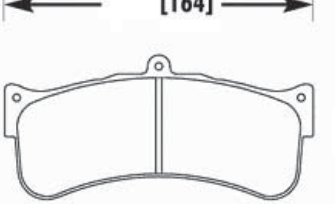
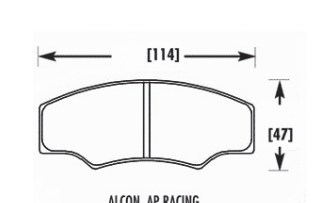
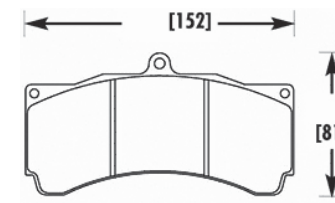
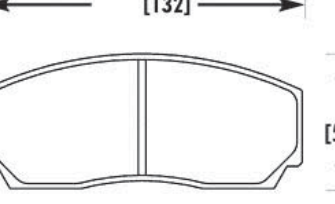
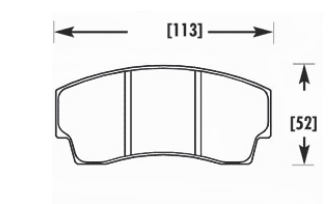
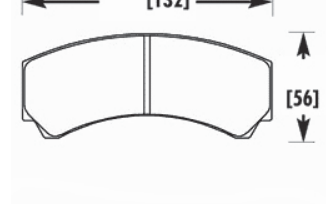
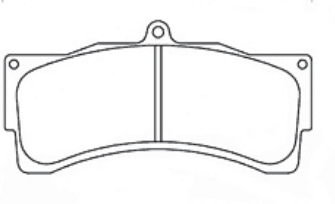
DRAWING	FAMILY	DRAWING	FAMILY
 <p>[140] [70] AP RACING, BREMBO, WILWOOD</p>	B19	 <p>[164] [66] BREMBO</p>	B22
 <p>[164] [66] AP RACING, BREMBO TRANS AM</p>	B23	 <p>[164] [77] BREMBO</p>	B24
 <p>[114] [47] ALCON, AP RACING, FORMULA ATLANTIC</p>	B50	 <p>[152] [81] ALCON, AP RACING</p>	B51
 <p>[132] [56] ALCON, AP RACING</p>	B52	 <p>[113] [52] ALCON, AP RACING, FORMULA ATLANTIC</p>	B53
 <p>[132] [56] ALCON, AP RACING</p>	B54	 <p>[163] [81] ALCON, AP RACING</p>	B55

scale 1:25

**DRAWING**

**FAMILY**

**DRAWING**

**FAMILY**

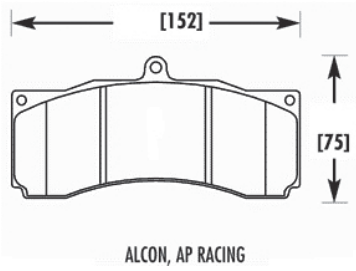

B56

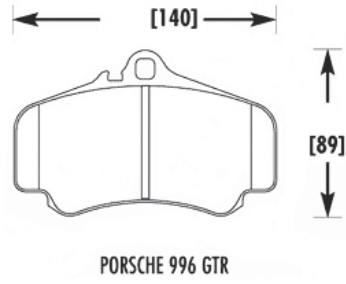

B57

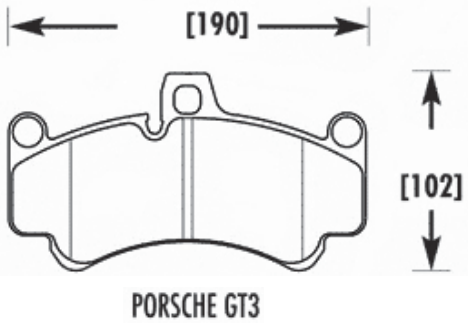

B58

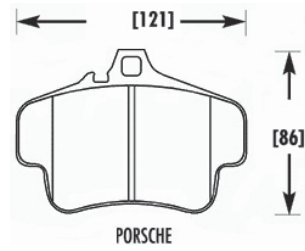

B59

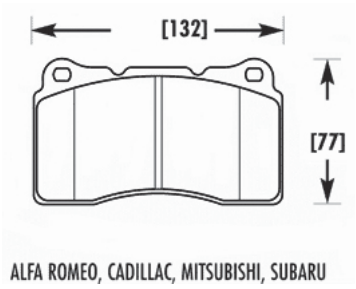

B62

scale 1:25